



Contents Overview

Chapter Overview

Type Index

R&S Addresses



"System integration with the aid of software and engineering efforts will be given more emphasis than ever before and the development of powerful and convenient system solutions take on importance."

Contents of chapter 8

Designation	Type	Description	Page
The future lies with system		Rohde & Schwarz system philosophy; service for systems	316
Production Test Systems	R&S®TS7110	Contents, test strategies	319
	R&S®TS7100, R&S®TS7180	Shielded RF test fixture	322
	R&S® CompactTSVP	Production Test Systems for Mobile Phones	322
	R&S®E-Line	Open Test Platform	327
		Extreme Temperature Tester	329
Type-Approval Systems for Mobile Radio	R&S®TS895x	Introduction, overview	330
	R&S®TS8960	RF Test System Family for GSM/GPRS/EDGE/3G Mobiles	331
	R&S®TS8965	RF Test System for <i>Bluetooth</i> ® Qualification and Compliance Test Systems	334
		RF Test System for <i>Bluetooth</i> ® Pre-Qualification	335
Coverage Measurement Systems	R&S®TS9955H	Introduction, overview	336
	R&S®TS9951, R&S®TS9958	High-Performance Coverage Measurement System	338
	R&S®TS9953	Portable Coverage Measurement System (GSM, DAB)	339
	R&S®TS9954	GSM Test Transmitter System	348
	R&S®UMTS PN-Scanner	Evaluation Software Roseval	350
		Drive test equipment for network planning, design, installation, optimization, quality assurance and service	351
	R&S®TSMU	Radio Network Analyzer	353
EMC Test Systems		Overview	355
	R&S®TS9970	RF Performance Test System	356
	R&S®TS9975	EMI Test System	358
	R&S®TS9976	Emission Test System	359
	R&S®TS9980, TS9981, TS9986,	EMS Test Systems	361
	R&S®TS998xM	EUT Monitoring System	366
	R&S®TS9994	EMS Test System	367
	R&S®TS-EMF	Portable System for EMF Measurements	368
	R&S®EMS-K1	EMS Software	370
	R&S®EMON-K1	CAN-Bus Monitoring	372
R&S®EMC32, R&S®EMC32E+	EMC Measurement Software, EMI Measurement Software	80, 82	



Contents Overview

Chapter Overview

Type Index

R&S Addresses





Contents Overview

Chapter Overview

Type Index

R&S Addresses



The future lies with systems

Customer-specific solutions are implemented to an increasing extent by integrating measuring instruments and specially developed devices into overall systems. This is proven by the valuable experience made with turnkey EMC test centers, type-approval test systems for mobile phones of digital radio networks, mobile test systems for coverage measurements and mobile phone production lines.

System applications

In numerous branches of industry measurements and tests often have to be carried out repeatedly on a series of DUTs, e.g. in:

- ◆ Incoming inspection: component or module tests
- ◆ Production: automatic alignment
- ◆ Quality assurance: testing at the various stages of production and final testing
- ◆ Research&development: series measurements on prototypes
- ◆ Service: long-time measurements (such as temperature) at defined test intervals

The quantity of devices under test required to make investments and software development worthwhile depends on the complexity of the measurement task. The necessary expenditure may even be justified for a few DUTs if a measurement is to be continuously repeated, e.g. at many different frequencies (intermodulation measurement of antenna amplifiers), or if a parameter is to be monitored as a function of time (long-term drift).

Project handling by Rohde & Schwarz

A high-performance measurement system requires extensive development and design efforts. The choice of the right instruments and components as well as their careful installation make for the high performance and availability of a system.

System design at Rohde&Schwarz ensures full utilization of a large variety of measuring instruments of advanced technology and highest precision both of Rohde&Schwarz and other make. System responsibility lies always with Rohde&Schwarz, irrespective of the origin of the measuring equipment and individual system components.

Rohde&Schwarz has experienced and optimally trained staff to implement a project from initial planning through to the operational system.

Our range of test systems

- ◆ Production test systems, board testers
- ◆ Type-approval test systems for mobile phones
- ◆ Coverage measurement systems for all modern radio networks
- ◆ EMC test systems and test centers

Production test systems, board testers – a strong concept

A development and production chain is only as strong as its weakest links which used to be highly complex measurement systems and time-consuming final testing. Market launch of the products was thus held up. Today, production test systems and type-approval systems from Rohde&Schwarz can be used wherever electronic equipment is produced. Efficient solutions in this field range from precompliance test equipment through to complete production lines.



Contents Overview

Chapter Overview

Type Index

R&S Addresses





Contents Overview

Chapter Overview

Type Index

R&S Addresses



The unique modular hardware and software concept of Rohde&Schwarz allows a large variety of test combinations with respect to alignment, RF test, optical check, board test, etc.

Our production test systems are tailored to the needs of the customers and provide overall solutions: measurements with DUT adaptation also in RF range via test prods; with conveyor belts; networking within user-specific computer network; logistics; consulting and advice in the selection of suitable tests for optimization of measurement times and test depth.

Type-approval test systems for mobile phones of analog and digital radio networks

Test systems from Rohde&Schwarz, especially for type-approval testing, are at the leading edge in their field. Our customers are benefiting from this high innovation potential. Specialists at Rohde&Schwarz have implemented well in-time the latest requirements for type-approval measurements in the appropriate test systems and were able to use ultramodern measuring equipment off our production. This synergy of available equipment and new system applications brings about optimum results. Thus it is for instance possible to achieve maximum test depth while ensuring the highest degree of ergonomics and operational reliability. And another great advantage is self-calibration. This means a whole bundle of benefits which the customer can utilize to make his products fit both for the future and present-day market.

Coverage measurement systems for all modern radio networks

Test systems from Rohde&Schwarz are not only used where electronics is produced but also where it is made to "work": in mobile radio networks for instance. Our range of mobile coverage measurement systems ensures full monitoring of analog and digital radio networks as well as smooth and best possible operation.

EMC test systems and test centers

Rohde&Schwarz supplies complete EMC test systems covering all aspects of this complex field. The manufacturer need no longer combine individual instruments – systems will do it. Whole EMC test chambers? No problem for Rohde&Schwarz: after handing over the turnkey system, all your staff trained by us has to do is to switch on the DUT and the test will be carried out fully automatically. This is to the benefit of test houses as well as manufacturers performing comprehensive EMI and EMS measurements themselves. The test systems from Rohde&Schwarz check for full compliance with all relevant standards.

Future-oriented design

Measurement and test systems from Rohde&Schwarz feature extremely flexible hardware and software concepts allowing adaptation to modified requirements any time.

Support

Test stations from Rohde&Schwarz are powerful instruments for increasing productivity in automated production. Rohde&Schwarz products include a complete service package, which allows the full performance of the system to be utilized from the very first day. This package includes training, application support, maintenance, fixture design, 24-hours spare parts service and a telephone hotline.

References

Measurement and test systems from Rohde&Schwarz are used to success all over the world: tailored to the needs of the customers, the test systems can be found at renowned industrial companies, test houses and government institutes – the impressive list of references can be supplied on request.



Contents Overview

Chapter Overview

Type Index

R&S Addresses





Service for systems

First-hand service

Rohde&Schwarz systems combine the latest achievements in hardware and software with the knowhow and experience gained over many decades. According to the Rohde&Schwarz system philosophy, the high level of competence does not stop with system development but is maintained during the operational life of the systems in terms of the services offered.

Hotline support, continuous updating of system software, fast replacement and repair of equipment and modules in case of a fault are essential prerequisites for high availability of an operational system.

Rohde&Schwarz offers complete packages and solutions for servicing the systems. The service concept is of modular structure and consists of unit blocks providing a whole series of services for hardware and software.

Services available

During warranty period

- ◆ Enhanced warranty service
 - Problem report service
 - Hotline service
 - Access to a pool of spare modules
- ◆ Calibration service

After warranty period

- ◆ After warranty service
 - Problem report service
 - Hotline service
 - Access to a pool of spare modules
- ◆ Software service
- ◆ Calibration service

Service products

Enhanced warranty service

The enhanced warranty service supplements the standard warranty services of Rohde&Schwarz to satisfy already during the warranty period the high demands placed on system availability and offers a service time of eight hours and defined response time.

- ◆ Database-supported information system with direct customer access
- ◆ Hotline service
- ◆ Access to a pool of spare modules
- ◆ On-site repair, if necessary
- ◆ Escalation procedure

After warranty service

The after warranty service contains all the unit blocks of the enhanced warranty service plus the following:

- ◆ Repair of faults
- ◆ Supply of software updates

Calibration service

The calibration service assures you that the parameters of your system will be checked at regular intervals and corrected if necessary.

- ◆ Calibration by an accredited calibration laboratory in line with EN ISO/IEC 17025
 - ◆ Calibration at specified calibration intervals in line with DIN EN ISO 9001
 - ◆ Traceability of calibration to national or international standards
 - ◆ Calibration reports and certificates
 - ◆ On-site calibration possible

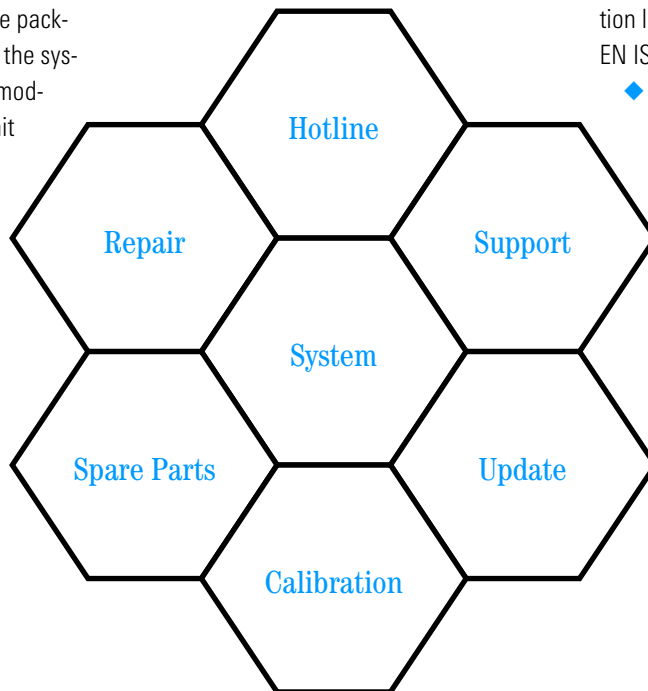



Contents Overview

Chapter Overview

Type Index

R&S Addresses



Production Test Systems – Contents

Designation	Type	Description	Page
Production Test Systems	R&S®TS 7110 R&S®TS 7100 R&S®TS 7180	Scalable solutions from low-cost standard system to turnkey production system	341
Open Test Platform	R&S® CompactTSVP	Automotive & Communication Test Solutions	327
Extreme Temperature Tester	R&S®E-Line	Temperature tests on wireless components in a shielded environment	329

Quality is measurable and testable

Quality management

Quality management is one of the central aspects of modern electronics production. Whatever the size of the company, the quality of the products depends on the electronic components functioning perfectly. The introduction of lean production methods has placed new and greater demands on automatic testing techniques.

Economy

Product quality, product liability

Today, excellent product quality is not only important in giving the edge in international competition but also saves cost. Our test systems help to eliminate defects early in production, thus preventing the high costs involved in the removal of defects in the final stages of production or after delivery to the customer.

In-depth testing is possible due to the wide range of precise measuring facilities provided by the workstations and test stations from Rohde&Schwarz, so faults can be detected early in production and their cause removed immediately.

Start small – upgrade later

Test stations from Rohde&Schwarz are more than simply autonomous testers – they have specifically been designed for integration into development, production and service. Fixtures and programs can be exchanged directly between the testers. The systems can thus be used to maximum effect: all test stations can be utilized optimally at all times; if the unit under test is large, subsequent upgrading to larger systems is no problem; fixtures can be adopted for servicing at any time.

Due to the modular design of the Rohde&Schwarz test stations, investment decisions can be made to satisfy the requirements of today, and, at the same time, options be left open for expanding capacity or testing new products as well as for incorporating future test strategies or supplementary test facilities at a later date. Investments, costs of adaptation and running costs of the test stations can be optimized for different products and production methods.

Low follow-up costs

Budget-priced fixture sets can be offered thanks to a standardized fixture interface. Thus costs of adaptation are low, which is of major importance for products manufactured in small quantities only. The reliable and easy-to-service concept ensures

high availability, so running costs are reduced to a minimum.

Electrical in-circuit test

Strategy

The electrical in-circuit test for a board checks all connections and the individual components independent of their environment.

This tried-and-tested method is an extremely reliable means of detecting and diagnosing the majority of typical manufacturing defects, such as shorts, opens, soldering and insertion defects. The influence of neighbouring components can be eliminated to a large extent, and a high degree of precision achieved, by means of 2-, 3-, 4- or 6-wire measurements, guarding and in-phase quadrature measurements. The measured values are stabilized, even under unfavourable conditions, by averaging and autodelay technique. The depth of testing is far superior to that of conventional prescreeners.

The electrical in-circuit test checks the following:

- ◆ Contact
- ◆ Shorts and opens
- ◆ Resistances, inductances and capacitances
- ◆ Impedances by magnitude and phase
- ◆ Diodes, Zener diodes, LEDs
- ◆ Transistors
- ◆ Multipole components such as potentiometers, relays, operational amplifiers, optocouplers



Contents Overview

Chapter Overview

Type Index

R&S Addresses



[Contents Overview](#)[Chapter Overview](#)[Type Index](#)[R&S Addresses](#)

Production Test Systems – Test strategies

Analog functional test

Strategy

Defined analog input signals are applied to the unit under test and the output signals are measured. This test checks all functions of the UUT and the interaction of its components.

Procedure

Rohde&Schwarz test stations provide all standard signals and measurement functions via appropriate stimulus and measurement modules. The signals are accessible either via very short paths at special fixed pins, or via the signal bus and the switch module at any pin.

The measurement equipment can be extended by adding CompactPXI and PXI modules.

The modules are equipped to trigger and synchronize (PXI trigger) with each other, the UUT, or external instruments. External IEC/IEEE-bus instruments can be connected to the test stations.

Digital functional test

Strategy

The digital functional test checks all functions of a digital circuit as close as possible to operating conditions.

It covers all technologies from SSI to VLSI, microprocessors, ASICs and SMDs. Digital input patterns are applied, and the output signals are measured and compared with the reference patterns.

Due to the varying complexity – from simple to complex VLSI boards – and the widely differing timing requirements, the user is given the opportunity of choosing the most economical of the various testing procedures available. The type of fixture can thus also be varied via the connectors of the UUT, the bed-of-nails (including 2-stage fixture), or probe.

Procedure

Dynamic functional test: Digital patterns (vectors) are applied to the connections of the UUT in realtime mode and with a high clock rate; the response is then measured and compared with the reference values.

Static functional test: Digital patterns are created and analyzed via computer. The result may lead to branching. Timing is not accurately determined.

Interface test: Optimized tests are available for different interfaces (RS-232-C, LAN, SPI).

Combinational test

The combinational test unifies various test strategies in a single tester with one program and one fixture, eliminating the handling time for separate testers. The user can select a combination which is specially tailored to his needs. This concept allows the peculiarities of customer-specific requirements to be taken into account, for instance the production environment, production quality, test strategy, complexity of UUT and special factors such as stipulated or impermissible test procedures, inaccessible nodes or varnished boards.

[Contents Overview](#)[Chapter Overview](#)[Type Index](#)[R&S Addresses](#)



Contents Overview

Chapter Overview

Type Index

R&S Addresses



Mobile radio – a dynamic market

The mobile radio market is undergoing dynamic changes and characterized by rapidly increasing production volumes, extremely short product cycles and a variety of mobile radio standards

Special design tools and chip sets today simplify mobile radio development, which has resulted in many new manufacturers entering this market and offering attractively priced products of their own. This leads to increasingly fierce competition.

Important developments on the mobile phone market

- ◆ Reduction of time to volume
- ◆ Reduction of production costs
- ◆ Re-usable test solutions for new products and new mobile radio standards
- ◆ Outsourcing to contract manufacturers
- ◆ New mobile radio manufacturers
- ◆ Use of reference designs from different chip set manufacturers
- ◆ Large local markets, e.g. China
- ◆ Test solutions from global manufacturers used as standard worldwide
- ◆ Global projects involving development teams and production plants around the world

Demands on production test solutions

- ◆ Minimization of costs per mobile radio unit, i.e. high throughput
- ◆ Standardized, easily adaptable solutions
- ◆ Production at any location around the world
- ◆ Easy integration of a company's own core competences
- ◆ Local support on a global scale



- ◆ Continuous development and upgrading to include new mobile radio standards
- ◆ Constant optimization, updating and further development of test platform
- ◆ Ready-to-use solutions for different reference designs
- ◆ Global project management

From the standard system to the turnkey solution

Our regional support and system integration centers will be glad to assist you in selecting and configuring a system that best suits your application and also integrate the system into your production line. Rohde&Schwarz offers you a complete spectrum of solutions and services for mobile phone production testing, thus minimizing time-to-volume and test costs while providing comprehensive test coverage.

Because of our many years of experience in mobile phone production testing – including with a variety of reference designs from chip set manufacturers – Rohde&Schwarz can offer optimized solutions that cover the entire spectrum from adjustment up to final testing.

To keep production running

Our regional system support and integration centers also provide system maintenance, repair and calibration as well as training of operating personnel. Maintenance contracts can be tailored to your specific requirements. Our experts assist you in optimizing new processes and also follow you when your production is relocated.



Contents Overview

Chapter Overview

Type Index

R&S Addresses





Contents Overview

Chapter Overview

Type Index

R&S Addresses



Shielded RF Test Fixture R&S®TS7110



Test fixture for modules and devices with a radio interface

Brief description

The R&S®TS7110 is a shielded test fixture for devices under test (DUTs) that have a radio interface, e.g. mobile phones, personal digital assistants (PDAs), remote keyless entry, cordless phones, and other small devices. The DUTs can operate on the basis of diverse radio standards such as GSM, WCDMA (UMTS), Bluetooth™*, WLAN or Home RF.

The test fixture was designed for the R&S®TS7100 (cPCI) and R&S®TS7180 (PC-based) production test systems. However, owing to its standardized USB interface and modular design, it can also be used in combination with other test systems. A DLL interface is provided on the software end to control the individual components. The test fixture is primarily used in production, but also in service, repair and quality assurance.

Main features

- ◆ Comprehensive concept for function tests (board and final tests as well user interface testing)
- ◆ RF- and audio-compliant setup of the test chamber
- ◆ Modular design
- ◆ Exchangeability of the DUT mount
- ◆ Upgradeability for new product versions
- ◆ Control via standardized USB interface
- ◆ Easy manual operation due to pneumatic support
- ◆ Status displays for user information
- ◆ Separate operating program for debugging or manual operation



The Shielded RF Test Fixture R&S®TS7110 with customer-specific configuration

Design and function

The semi-automatic Shielded RF Test Fixture R&S®TS7110 consists of a base and a hinged top with pneumatic support for easier opening and closing. The top contains a universal mount for the hold-down pieces that are used to position DUTs as well as other test fixtures for tasks that need to be carried out from the top of the DUT.

The base integrates the lower part of the RF chamber with the swapout unit including DUT mount. The test system interface is also housed here, containing the fixture control as well as additional built-ins, signal conditioning and level converters for communicating with the DUT. Mechanically standardized interfaces make it easy to exchange the swapout unit for testing other devices or models with similar testing tasks.

Shielded test chamber

When RF modules are tested, external sources of interference (nearby base stations, adjacent test systems, etc) must always be taken into account.

To sufficiently suppress these signals, the test fixture is shielded against high-frequency interference. Pneumatic lines are routed through special wall feedthroughs, electrical signals through RF feedthroughs or sub-D connectors with filters. RF and audio absorbers can also be installed to prevent interference due to reflections in the test fixture.

Universal antenna couplers are provided for testing wireless interfaces in the RF range. They are available for all common frequency bands as used, for example, with 2G and 3G mobile phones, network adapters, WLAN, or Bluetooth.



Contents Overview

Chapter Overview

Type Index

R&S Addresses



Shielded RF Test Fixture R&S®TS7110

Applications

The fully modular concept of the RF test fixture allows a wide variety of components for almost any task such as the following to be integrated:

- ◆ Electrical testing of printed board assemblies on one or both sides
- ◆ RF tests via antenna couplers that can be integrated
- ◆ Audio tests using the audio set
- ◆ Keyboard tests with pneumatic fingers
- ◆ Tests of displays with CCD cameras
- ◆ Tests of built-in cameras with illuminated test patterns
- ◆ Testing of interfaces and components such as memory cards, etc

The elevated cover provides sufficient room for integrating CCD cameras.

Making a significant number of project-specific adaptations is always necessary since manufacturers have highly diverse test requirements and the layouts of DUTs can differ widely from one to the next.

This affects not only the DUT mount but also the position and scope of mechanical, electrical and optical components.

Control

The test fixture control is integrated completely in the generic test software library (GTSL) by Rohde & Schwarz. For more information, refer to the data sheets for the Production Test Platforms

R&S®TS7100 (PD 0757.5737) and R&S®TS7180 (PD 0757.7469).

The test fixture can also be controlled via a DLL and the operator panel.

Either a Rohde & Schwarz integration center, an authorized systems house or the individual user can implement this customer-specific application. The modular concept allows users to combine or modify components that have been adapted to operate together.

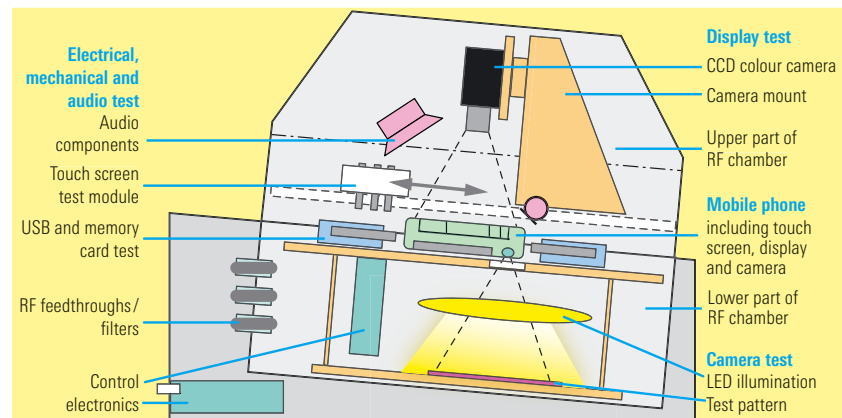

Setup of the test fixture for final tests including display and camera tests

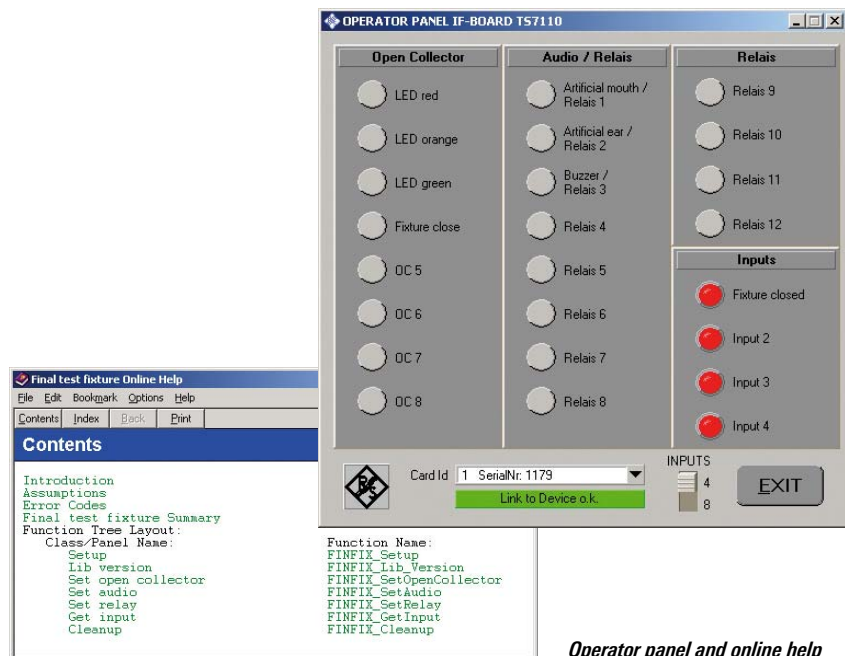

Operator panel and online help



Contents Overview

Chapter Overview

Type Index

R&S Addresses



Shielded RF Test Fixture R&S®TS7110

Specifications

Basic unit

Dimensions	
Test fixture (W x D)	41 cm x 60 cm
Height (closed)	36 cm, with camera 44 cm
Height (open)	60 cm
DUT max. (W x D)	13 cm x 22 cm
Height (with acoustic installation kit)	5 cm
Height (w/o acoustic installation kit)	14 cm
Weight	
Without options	14 kg
With typical options (absorber, fixture interface card, acoustic installation kit, antenna)	19 kg
Temperature ranges	
Operating temperature range	+10°C to +40°C
Storage temperature range	-20°C to +60°C
Relative humidity	
In operation	90% r.h. at +10°C to +30°C
In storage	75% r.h. at +30°C to +40°C 90% r.h. at +60°C
Required resources	
	compressed-air connection, AC supply voltage (see Fixture interface card)
Connectors	
In the test fixture housing (base unit)	
Pneumatics: hose diameter	6 mm
Compressed air	0.4 Mpa to 0.7 Mpa filtered 5 µm, oiled/non-oiled for max. 6 magnetic valves
Pneumatics block	
Line feedthrough (W x H)	4.5 cm x 3 cm
Connection board (W x H)	25 cm x 10.5 cm (usable)
Ground connection	thread bolt M5 x 15 and pushbutton connection
Connection board in the RF housing	
RF	2x SMA – SMA connector
Pneumatics	8x Schott screw connection for hose connection (3 mm internal diameter)
Audio	9-contact, sub-D, filtered
Data	15-contact, sub-D, filtered
Power + unused connectors	25-contact, sub-D, filtered
RF shielding	
	without absorber with absorber. (option)
450 MHz to 600 MHz	>65 dB >75 dB
800 MHz to 1000 MHz	>60 dB >75 dB
1700 MHz to 2000 MHz	>55 dB >65 dB
2000 MHz to 2500 MHz	>45 dB >65 dB
AF shielding	
200 Hz to 400 Hz	>12 dB
400 Hz to 1000 Hz	>16 dB
1000 Hz to 4000 Hz	>23 dB

Fixture interface card (optional)

Interface to test system	
Power supply (external power supply unit)	$V_{in} = 100 \text{ V AC to } 240 \text{ V AC, } 1.5 \text{ A, } 50 \text{ Hz to } 60 \text{ Hz, } V_{out} = 24 \text{ V DC, } 3 \text{ A}$ via R&S®TS-PRL1 from R&S®TS7000 series
Interface to test system	
Hardware	1x USB or R&S®TS-PRL1 (R&S®TS7100) interface board on exterior housing 2x BNC for audio 1x sub-D each for DUT power supply and control (RS-232-C) GTSL (R&S®TS7100, R&S®TS7180)
Software	
Internal interfaces to fixture control and DUT	
Digital inputs	4 or 8 high active, max. 24 V DC, $V > 4 \text{ V high}$
Digital outputs	8x open collector, max. 300 mA, 30 V
Audio input	1:2 multiplexer
Amplifier to artificial mouth	-70 dB to +5 dB, V_{in} max. 5 V (V_{rms}), P_{out} max. 2 W into 8 Ω
Amplifier to DUT	-34 dB to 0 dB V_{in} max. 5 V (V_{rms}), V_{out} max. 5 V (V_{rms})
Audio output	2 microphone amplifiers from artificial ear or buzzer
Amplifier from DUT	3:1 multiplexer 0 dB to +40 dB, 5 V bias differential input -12 dB to +28 dB, V_{in} max. 5 V (V_{rms}), V_{out} max. 5 V (V_{rms})
Relays	8 or 12 SPST, max. 500 mA, 30 V, can be connected to DMM from DUT power supply
DUT control RS-232-C	via level converter, max. 250 kbps Rx/D, Tx/D, RTS, CTS, GND, voltage adjustable between 3.0 V and 3.6 V
USB	full speed, high speed (special filters/fiber optic cables required)

Antenna coupler (optional)

Type 1	e.g. GSM, WCDMA
Frequency ranges	770 MHz to 1000 MHz 1700 MHz to 2200 MHz
Coupling factors	8 dB to 25 dB, depending on frequency and DUT
Connector	SMA
Type 2	e.g. Bluetooth
Frequency ranges	2400 MHz to 2550 MHz 1700 MHz to 2200 MHz
Coupling factors	20 dB to 30 dB, depending on frequency and DUT
Connector	SMA
Type 3	e.g. WLAN
Frequencies	2.4 GHz 5.2 GHz 5.75 GHz
Connector	SMA

Acoustic installation kit (optional)

Components	
Artificial mouth	
Frequency range	250 Hz to 4 kHz
Artificial ear	
Frequency range	200 Hz to 4 kHz



Contents Overview

Chapter Overview

Type Index

R&S Addresses





Contents Overview

Chapter Overview

Type Index

R&S Addresses



Shielded RF Test Fixture R&S®TS7110

Ordering information

Example packages *)	Type, order number	Package A Basic model	Package B Automatic module test	Package C Automatic final test I	Package D Automatic final test II	WU
Application		Test of devices or modules that require an RF chamber – Manual connection of the DUT e.g. R&D, service**)	Automatic test of electronic modules with – Automatic contact e.g. for production**)	Automatic test of devices with – Automatic contact – Radio interface – Audio interface e.g. for production**)	Automatic test of devices with – Automatic contact – Radio interface – Audio interface – Display (colour) e.g. for production**)	R&S®TS-F1A
Included components		– Control – Universal exchangeable plate Option packages – A: Acoustic set Image processing components ***): – B: Monochrome – C: Colour	– Control – Exchangeable plate kit – Pneumatic set for swapout unit and hold-down piece – Hold-down plate Option packages – A: Acoustic set Image processing components ***): – B: Monochrome – C: Colour	– Control – Exchangeable plate kit – Acoustic set – Antenna coupler – Pneumatic set for swapout unit and hold-down piece – Hold-down plate – Absorber Option packages Image processing components ***): – B: Monochrome – C: Colour	– Control – Exchangeable plate kit – Acoustic set – Antenna coupler – Pneumatic set for swapout unit and hold-down piece – Elevated cover – Hold-down plate – Camera mount – Cable+filter for colour camera***) – Keyboard test – Absorber	X * R&S®TS-7110-C1 = working units for installing and testing the options in the R&S®TS-F1A
Base unit Housing with – Basic pneumatic equipment such as pressure regulator and closing device – Status display RF chamber with – Pneumatic feedthroughs and 3 filter connectors – Mounts for swapout units below and hold-down plate above	R&S®TS-F1A 1152.6007.02					4
Control Card for R&S®TS-F1A – RS-232-C, R&S TSVP interface – USB interface (1.1 and 2.0, slow speed) – Audio interface	R&S®TS-F111 1152.6307.02	✓	✓	✓	✓	3
External 24 V AC Power Supply	R&S®TS-PS24 1152.6459.02	✓	✓	✓	✓	–
Cable Set for Connection to R&S®TS7180	R&S®TS-F1C1 1152.4904.02	☺	☺	☺	☺	–
Absorber Set for Base Unit R&S®TS-F1A	R&S®TS-F1B 1152.6107.02	☺	☺	✓	✓	4
Swapout Unit (kit) with 96-contact VG connector (female) or Mounted Swapout Unit + self-adhesive pad	R&S®TS-F1P1 1152.6207.02	–	✓	✓	✓	**)
	R&S®TS-F1P1UN 1165.1673.02	✓	–	–	–	1
Pneumatic Set, 4x Valves, hoses, couplers+hardware or	R&S®TS-F1PNE4 1165.1680.02	☺	✓	✓	☺	**)
Pneumatic Set, 8x (2x R&S®TS-F1PNE4, 4 connecting pieces)	R&S®TS-F1PNE8 1165.1696.02	☺	☺	☺	✓	**)



Contents Overview

Chapter Overview

Type Index

R&S Addresses



Shielded RF Test Fixture R&S®TS7110

Example packages *)	Type, order number	Package A Basic model	Package B Automatic module test	Package C Automatic final test I	Package D Automatic final test II	WU
Hold-Down Plate for customer-specific configuration or	R&S®TS-F1P2 1165.1709.02	☺	✓	✓	✓	**)
Assembly Set for acoustic set und DUT hold-down piece	R&S®TS-F1MA1 1165.1715.02	☺ (for option package A/B/C)	–	–	–	1
GSM Antenna Coupler	R&S®TS-F1N1 1152.6259.02	☺	☺	✓	✓	1
Bluetooth Antenna (without assembly material)	CMU-Z12 1150.1043.02	☺	☺	☺	☺	**)
WLAN Antenna (without assembly material)	TW-614/S 1153.4008.00	☺	☺	☺	☺	**)
Acoustic Set	R&S®TS-F1A1 1152.6407.02	J (for option package A)	J (for option package A)	✓	✓	1
Video Lowpass Filter	R&S®TS-FI-LPV 1165.1721.02	B: ☺, C: ☺☺ (for option package B/C)	B: ☺, C: ☺☺ (zu Optionspaket B/C)	B: ☺, C: ☺☺ (for option package B/C)	✓✓	1
Cable Set for BW camera (BAS)	R&S®TS-FC-BAS 1165.1738.02	☺ (for option package B)	☺ (for option package B)	☺ (for option package B)	–	1
Cable Set for colour camera (S video, Y/C)	R&S®TS-FC-YC 1165.1521.02	☺ (for option package C)	☺ (for option package C)	☺ (for option package C)	✓	1
Camera Mount for Hold-Down Plate R&S®TS F1P2	R&S®TS-F1P2MC 1145.6486.12	–	☺ (for option package B/C)	☺ (for option package B/C)	✓	1
Camera Mount for Assembly Set R&S®TS F1MA1	R&S®TS-F1MC1 1145.6486.02	☺ (for option package B/C)	–	–	–	1
Cover for camera installation	R&S®TS-FCBV 1145.6470.02	☺ (for option package B/C)	☺ (for option package B/C)	☺ (for option package B/C)	✓	1
Absorber Set for R&S TS-FCBV	R&S®TS-F1D 1165.1444.02	☺ (for option package B/C)	☺ (for option package B/C)	☺ (for option package B/C)	✓	2
Assembly and Test of the Shielded RF Test Fixture R&S®TS7110 (1x R&S®TS-7110C1 = 1 working unit)	R&S®TS-7110C1 1156.3054.10	Example of package A: requires 8x R&S®TS-7110C1	Example of package B: requires 8x R&S®TS-7110C1	Example of package C: requires 14x R&S®TS-7110C1	Example of package D: requires 20x R&S®TS-7110C1	
Adaptations By the user or as a project together with the Rohde & Schwarz Production Test Department						
Modification of Base Unit R&S®TS-F1A	R&S®TS-F1AMOD 1165.1480.xx					
Modification of swapout unit +hold-down piece	R&S®TS-F1ADAB 1145.6286.xx					

Examples of typical configurations

- 1) Other configurations on request.
- 2) Customer-specific adaptation by the user or implementation via Rohde & Schwarz.
- 3) Camera, frame grabber and cable for frame grabber not included.

We reserve the right to make design changes corresponding to advances in technology.

For further information, visit www.hf-adapter.rohde-schwarz.com.



Contents Overview

Chapter Overview

Type Index

R&S Addresses



Open Test Platform R&S® CompactTSVP



Automotive & Communication

Test Solutions

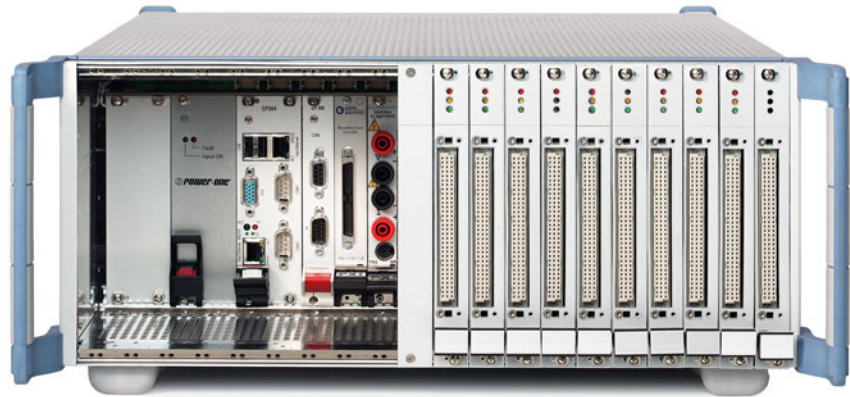

Brief description

The R&S®TSVP (Test System Versatile Platform) technology represents a whole family of products developed for high-performance ATE applications. The chassis comprises a mechanical frame, digital backplanes and bridges (if applicable), analog backplane, mains switching and filtering, power supply and diagnostic extensions.

Main features

- ◆ CompactPCI backplane conforming to PICMG 2.0 Rev. 3.0 specification
- ◆ Rear I/O support for easy system cabling (IEEE 1101.11-1998)
- ◆ Supports two 47-pin connector redundant power supplies
- ◆ Front plug-in power supply unit for easy maintenance
- ◆ Supports 14 peripheral slots for versatile instrumentation
- ◆ Sophisticated analog measurement bus subsystem
- ◆ Common diagnostic features for all instrumentation modules
- ◆ Internal analog and trigger bus providing PXI functionalities
- ◆ Easy expandable ATE switching
- ◆ Cost-effective peripheral control for switching units via CAN

- ◆ Based on industrial standards
- ◆ Test and measurement modules with floating inputs available
- ◆ Comprehensive driver support including soft front panels

Test and Measurement Platform R&S® CompactTSVP

The industrial chassis for modular instrumentation includes one power supply and is prepared to accommodate an additional power supply, which allows parallel operation or DUT-specific supply. The new generation system platform is based on industrial standards and extended by the high-accuracy R&S®TSVP analog bus.

The CompactPCI/PXI backplane provides 14 peripheral slots with additional CAN serial control lines. An external CAN port for the R&S®PowerTSVP control is included.

Switching Application Platform R&S® PowerTSVP

The R&S®PowerTSVP is an industrial chassis frame for complex and modular switching applications, a new generation system platform based on industrial standards and extended by the high-accuracy R&S®TSVP analog bus.

It is controlled by the R&S®TS-PCA3 CompactTSVP or various CAN interfaces available for PCs and notebooks.

R&S® CompactTSVP Measurement Modules

You can choose from various modules suitable for industrial use in research, development and production. Designed for ATE applications (automated test equipment), the modules provide common features, such as analog bus access for seamless signal routing, diagnostics, soft front panels and high-performance driver software.

Analog Source and Measurement Module R&S®TS-PSAM

The R&S®TS-PSAM module contains a discharge circuit, a floating, programmable source and a fast measurement unit. DUT signals can be retrieved from the analog bus of the R&S®CompactTSVP by means of relays. The trigger logic of the measurement unit is linked to the PXI trigger lines. Two 4-channel relay multiplexers are available in addition.



Contents Overview

Chapter Overview

Type Index

R&S Addresses





Contents Overview

Chapter Overview

Type Index

R&S Addresses



Open Test Platform R&S® CompactTSVP

In-Circuit Test (ICT) Extension Module R&S® TS-PICT

The ICT extension module comprises an AC stimulus and a special current measurement unit for guarded impedance measurements in conjunction with the R&S® TS-PSAM module.

Digital Functional Test Module R&S® TS-PDFT

The R&S® TS-PDFT is a digital function test module with a high number of dynamic digital I/O channels as well as automotive communication interfaces. The innovative technology and versatile functionality provide excellent suitability for automotive and high-performance T&M applications.

Arbitrary Waveform and Function Generator Module R&S® TS-PFG

The R&S® TS-PFG is a two-channel, floating and arbitrary waveform generator with a CompactPCI interface. Its innovative technology and high functionality makes it ideal for automotive applications. The module is used wherever one-channel or multichannel analog output signals are to be stimulated.

Analyzer and Data Acquisition Module R&S® TS-PAM

The R&S® TS-PAM is a two-channel simultaneous waveform analyzer with CompactPCI interface.

Both conversion paths can be operated with a 4-channel multiplexer. The programmable measurement range and scan operation permit a variety of signal configurations to be measured. Comprehensive trigger capabilities and differential inputs enable flexible data acquisition particularly in R&D labs, quality assurance and product re-verification in production.

R&S® CompactTSVP and R&S® PowerTSVP Switching Modules

Designed for the CAN bus as a cost-effective control interface, the R&S® TSVP switching modules provide signal interconnection from the DUTs to the modular instrumentation units. The modules provide common features such as analog bus access, diagnostics, soft front panels and high-performance driver software.

Switching Matrix Module R&S® TS-PMB

The matrix module B allows test points or test devices to be interconnected either locally or via the analog measurement bus. The module can be used in the R&S® CompactTSVP and the R&S® PowerTSVP. The built-in self-test capability makes it possible to check the module within the system.

Power Switching Module R&S® TS-PSM1

The R&S® TS-PSM1 is a power switching module controlled by the CAN bus. Its innovative technology and versatile functionality make it ideal for automotive and high current switching applications in power management and test load paradigms. For measuring high currents, shunts are integrated on-board. It is used wherever high voltage or currents have to be switched or distributed.

Ordering information

Open Test Platform R&S® CompactTSVP and R&S® PowerTSVP

Chassis		
Test and Measurement Platform	R&S® TS-PCA3	1152.2518.02
Switching Application Platform	R&S® TS-PWA3	1157.8043.02
Modules		
Analog Source and Measurement Module	R&S® TS-PSAM ¹⁾	1142.9503.02
In-Circuit Test (ICT) Extension Module	R&S® TS-PICT ¹⁾	1158.0000.02
Digital Functional Test Module	R&S® TS-PDFT	1143.0080.02
Arbitrary Waveform and Function Generator Module	R&S® TS-PFG ¹⁾	1158.0052.02
Analyzer and Data Acquisition Module	R&S® TS-PAM ¹⁾	1158.0100.02
Switching Matrix Module	R&S® TS-PMB	1143.0039.02
Power Switching Module	R&S® TS-PSM1	1143.0139.02

¹⁾ Including R&S® TS-PDC isolated DC-supply module.



Contents Overview

Chapter Overview

Type Index

R&S Addresses





Contents Overview

Chapter Overview

Type Index

R&S Addresses



Extreme Temperature Tester R&S®E-Line

Temperature tests on wireless components in a shielded environment

Brief description

The Extreme Temperature Tester R&S®E-Line is a measurement environment for wireless RF devices (e.g. mobile phones, *Bluetooth* devices, and remote keyless entry systems).

The R&S®E-Line combines a shielded environment with a temperature-controlled chamber. Used as a test sequencer, the R&S®TSVP allows several devices to be measured in the same test run.

The R&S®E-Line is software-controlled and handles all communication with the measurement system (e.g. a production test system from Rohde&Schwarz).



Main features

- ◆ Test of different DUTs and/or standards (e.g. GSM, WCDMA, *Bluetooth*) in the same test run
- ◆ Up to 12 DUTs
- ◆ Cost reduction of up to 80% compared to discrete solution (equipment and test time)
- ◆ Temperature range -40°C to $+80^{\circ}\text{C}$ (according to automotive component standards)
- ◆ Runs with any existing test system (e.g. production/conformance/QA test systems from Rohde&Schwarz)
- ◆ System software based on TestStand

Specifications

Electrical data	
Frequency range	0.5 GHz to 3 GHz
Shielding effectiveness	>60 dB
RF connectors	N type
Temperature	
Temperature range	-40°C to $+80^{\circ}\text{C}$
Temperature change rate	3.5°C/min, typ.

General information	
Height	2 m
Width	19" rack
Position of DUT panel	1 m above floor
Test volume	>150 l
6 HU for other devices are provided inside of the shielded part	
R&S®E-Line is mounted on ESD wheels	
General feedthroughs within the system	RS-232-C, VGA, Ethernet, mouse and keyboard, mains, air inlet
Mains supply	380 V AC, 3 phase



Contents Overview

Chapter Overview

Type Index

R&S Addresses





Contents Overview

Chapter Overview

Type Index

R&S Addresses



Type-Approval Systems for Mobile Radio



International benchmark for mobile radio test technology

Before being allowed onto the market, each and every mobile phone has to undergo a comprehensive series of checks which is referred to as the full compliance test (FTA). Rohde & Schwarz is the most important provider of system simulators of this kind for the world's most successful digital mobile radio systems.

System solutions for all significant mobile radio systems

We provide a whole range of integrated systems and components for full compliance tests on mobiles. The approach we offer is technically innovative, practice-oriented and gives optimal performance and user-friendliness.

Type	Designation	Applications	Page
R&S®TS8950G	RF Test System for GSM/GPRS/EDGE Mobiles	Reliable RF testing all the way from development to conformance testing	331
R&S®TS8950W	RF Test System for WCDMA Mobiles		331
R&S®TS8960	Bluetooth® Qualification and Compliance Test Systems	Full compliant to Bluetooth® RF test specification	334
R&S®TS8965	RF Test System	Ideal test solution for RF pre-qualification and quality assurance in the development process	335

We set the standards – you enjoy the benefits

With our compliance systems, you are ensured a high level of standard conformity and result reproducibility. This is why they have been accepted as standard test tools by test houses and accredited testing organizations all over the world. Mobile radio manufacturers know that equipment that has been developed using our systems will have no problems with official acceptance tests. You can be sure of the successful outcome of approval procedures without any bother.

Future-proof thanks to high flexibility

The most striking features of the test systems from Rohde & Schwarz are the highly flexible hardware and software concepts which can be adapted to any changes in standards and any new technical requirements. Service packages tailored to your individual requirements secure your investment in equipment and keep your equipment at the leading edge of technology.



Contents Overview

Chapter Overview

Type Index

R&S Addresses





Contents Overview

Chapter Overview

Type Index

R&S Addresses



RF Test System Family R&S®TS895x

**Reliable RF testing all the way
from development to conformance
testing**

R&S®TS8950G

for GSM/GPRS/EDGE mobiles

R&S®TS8950W for 3G mobiles

R&S®TS8955G/R&S®TS8955W

for prequalification



Brief description

The R&S®TS8950G/TS8950W are designed to perform RF tests of the transmitter and receiver of GSM/WCDMA mobile phones. These tests cover, for instance, measurements of the output spectrum produced by the mobile to evaluate the signal quality and to check possible interference with other services. For the receiver tests, interfering signals are added and signal propagation conditions are simulated using a fading simulator. In this case, the R&S®TS8950G/TS8950W measure the receiver sensitivity to these disturbances by calculating the information loss (BER, BLER, FER). The test functionality of the R&S®TS8950G/TS8950W is implemented as test methods. Each test method provides a generic test application and is fully configurable. Test cases are described by parameter sets. This provides significant benefits:

- ◆ Easy variation of test parameters for testing above and below the pre-defined test limits
- ◆ Fast definition of new tests (for development)
- ◆ Consistency between development tests and conformance tests
- ◆ Clearer view on the real performance of the mobile phone

Main features

- ◆ TS8950G for RF tests according to 3GPP TS51.010-1, section 12, 13, 14, 21 and 22
- ◆ TS8950W for RF tests according to 3GPP TS34.121, section 5, 6 and 7
- ◆ Freely configurable RF test methods for R&D
- ◆ Supports GSM Ph2/Ph2+, GPRS, EDGE and AMR
- ◆ Supports WCDMA
- ◆ Open interfaces for easy integration into individual lab concept
- ◆ Control of custom equipment

Applications

Development of GSM mobile phones

Each of these test packages includes a fully configurable test method and example parameter sets. All parameters can be freely varied through the graphical user interface. The measurement results can be analyzed either with the R&S®TS8950 control center or with other customer-specific software tools.

Conformance testing of GSM mobiles

Together with the test methods, the parameter sets for the relevant test cases to 3GPP TS51.010-1 and 3GPP TS34.121 are supplied as write-protected, frozen files. All test cases will be validated by independent test houses.



Contents Overview

Chapter Overview

Type Index

R&S Addresses





Contents Overview

Chapter Overview

Type Index

R&S Addresses



RF Test System Family R&S® TS 895x

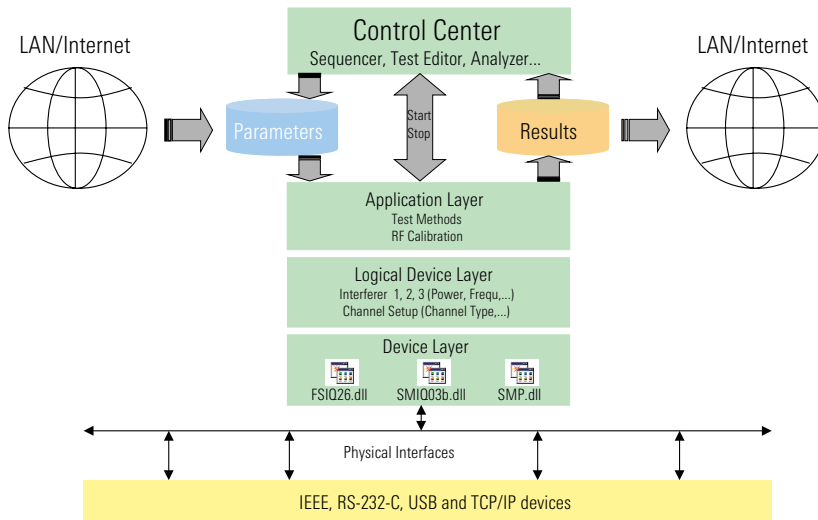

R&S® TS 8950 software structure

Platform concept

The R&S® TS 8950G/TS 8950W test system has been developed as a true platform to cover the full range of mobile phone RF tests. The test philosophy of the R&S® TS 8950G/TS 8950W is to have one core system for all extension levels. This core system ensures measurement accuracy and provides appropriate interfaces at the hardware and software level, allowing user friendly system configuration. The R&S® TS 8950G/TS 8950W is available with different extension levels:

Receiver performance test systems R&S® TS 8955G/TS 8955W

The lowest extension level of the includes a Radio Communication Tester R&S® CMU 200 as the signalling unit and BER tester, with one or more signal generators to produce interfering signals and with a baseband fading simulator. The purpose of this minimum configuration is to evaluate the performance of a mobile receiver. If more detailed protocol functionality is required, a Universal Protocol Tester R&S® CRTU-G for GSM can be installed instead of the R&S® CMU 200.

Basic RX/TX test system

This system is equipped with the basic RF equipment including a vector signal analyzer. The signalling unit in the basic RX/TX test system is either a R&S® CMU 200 (R&S® TS 8955) or a R&S® CRTU-G (R&S® TS 8950) protocol tester.

Full-performance RF test systems R&S® TS 8950G/R&S® TS 8950W

The full system with R&S® CRTU-G protocol tester and band-specific signal conditioning units (ASCUs) for each GSM band is the solution for conformance testing. It allows full comparison with measurement results obtained by means of one of the low-extension versions.



Contents Overview

Chapter Overview

Type Index

R&S Addresses



[Contents Overview](#)[Chapter Overview](#)[Type Index](#)[R&S Addresses](#)

RF Test System Family R&S®TS895x

Customizing the system configuration

The R&S®TS8950 control center RS-PASS allows flexible device handling: Instruments can be easily integrated into the system or removed from it without downtime. The instruments' capabilities are abstracted in a logical device layer, making the system widely independent of the individual instruments.

Custom control/analysis

The test methods in the R&S®TS8950G/TS8950W are single executable files. This allows also the use of other software tools for system control, so that existing lab automation software can be extended to control the R&S®TS8950G/TS8950W. Parameter files and result files can be accessed from anywhere within the company network so that test design and analysis can be performed offline allowing optimum utilization of human and test resources.

Access to the signal path

The R&S®TS8950 switch unit provides access to both transmit and receive signal paths. Multiple RF connectors at the rear of the switch unit allow the introduction of customer-specific signal conditioning elements whenever required.

Further Characteristics

RF Path Calibration

The signals within the R&S®TS8950G/TS8950W systems are routed through a signal switching and conditioning unit. So no manual changes of the measurement setup, which can cause unpredictable path losses and phase shifts, are required. The switch unit has been optimized for reliability and accuracy. All signal paths used by the test applications are automatically calibrated for frequency-dependent losses. This includes connectors and different DUT (device under test) cables. The fixed internal cabling makes the switch unit insensitive to phase shifts. The R&S®TS8950 system monitors the performance of the RF paths to ensure optimum consistency and reproducibility of measurement results, which leads to a maximum confidence level.

Temperature monitoring

To further increase the information obtained by the tests executed, it is possible to monitor and record the temperature of the test site and the DUT with up to 3 PT100 probes.

Extensions/upgradability

The R&S®TS8950G/TS8950W is designed for RF testing of GSM/GPRS/EDGE/3G mobiles operating in the GSM 850/900/1800 or GSM 1900 frequency band and three WCDMA bands (FDDI, FDDII and FDDIII). Extensions for other frequencies are easily possible. The R&S®TS8950GW is a combined test system for GSM and WCDMA.

[Contents Overview](#)[Chapter Overview](#)[Type Index](#)[R&S Addresses](#)



Contents Overview

Chapter Overview

Type Index

R&S Addresses



Bluetooth Qualification and Conformance Test Systems R&S®TS8960



Conformance Test System for Bluetooth RF Qualification, validated by Bluetooth SIG

Brief description

R&S®TS8960 is a qualification measurement system that is based on the *Bluetooth* Core Specification 1.2 and the *Bluetooth* RF Test Specification 1.2 which contains the obligatory RF measurements for the qualification of *Bluetooth* devices. The system can be used for conformance testing as well as for testing during the development phase and quality assurance process. For this purpose, the parameters of the test cases can be changed in a wide range.

Besides the test cases, the system offers a sophisticated software for RF path compensation. The wanted and interfering signals as well as the signal from the EUT are combined or split, attenuated or amplified, filtered and switched in a signal switching and conditioning unit (SSCU).

In addition to path compensation, the system offers a selftest. During this test, the main functions of the system devices are checked to ensure specification-conformant execution of the test cases. During the execution of the application programs (selftest, path compensation and test cases) a detailed test report is generated. The automatically generated test reports with measurement diagrams are suitable for submittal to the BQB (Bluetooth Qualification Body) to obtain qualification for the *Bluetooth* device under test.



The system is controlled via a graphical user interface. The software platform is LINUX (version 7.3), the graphical user interface is based on the Qt Library.

- ◆ Comprehensive selftests and high measurement accuracy due to automatic path compensation
- ◆ Additional options: remote control of climatic chamber, etc.

Main features

- ◆ All test cases to *Bluetooth* RF Test Specification v1.2 implemented as automatic test routines (for qualification)
- ◆ All test cases executable with variable parameters (for development and optimization)
- ◆ Additional test cases (free receiver, search sensitivity)
- ◆ Signalling unit for "Signalling" test mode upgradeable to protocol tester (R&S®PTW60) for *Bluetooth*® signalling tests according to test specification 1.1

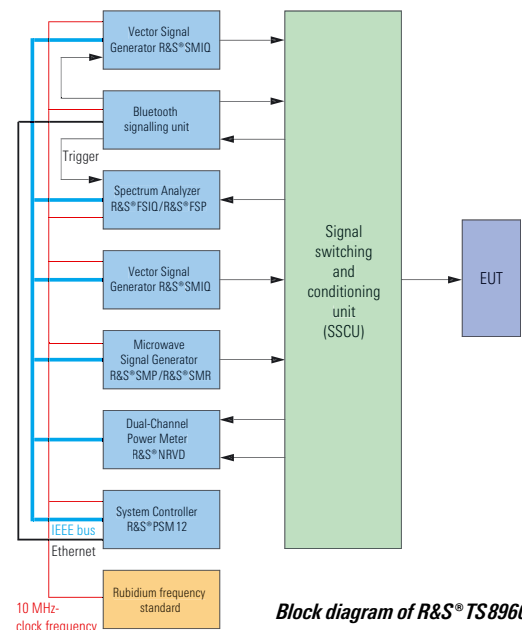

Contents Overview

Chapter Overview

Type Index

R&S Addresses





Contents Overview

Chapter Overview

Type Index

R&S Addresses



RF Test Systems R&S®TS8965

Ideal test solution for RF pre-qualification and quality assurance in the development process



Brief description

The R&S®TS8965 offers an ideal test solution for RF pre-qualification and quality assurance in the development process. The RF test system is adapted to the *Bluetooth*® Core Specification 1.2 and the *Bluetooth*® RF test specification 1.2, which defines the RF measurements for the qualification of *Bluetooth*® devices.

In the basic version the R&S®TS8965 is able to support 8 test cases, i.e. 7 transmitter and 1 receiver test cases. By adding further software and hardware options the R&S®TS8965B can be upgraded to a pre-qualification RF test system that supports all 15 RF test cases (non-compliant) of the above mentioned test specification plus the spurious emissions test case of test specification 1.1.

Main features

- ◆ Cost-efficient RF test system for *Bluetooth*® RF development and verification
- ◆ Performs all in-band transmitter test cases and maximum input level receiver test case in basic version (non-compliant)
- ◆ Extendable to the full set of 15 + 1 test cases, i.e. 5 test cases by software upgrade and 3 test cases by hardware and software upgrade (non-compliant)
- ◆ The R&S®TS8965 can be upgraded to the full qualification *Bluetooth*® RF Test System R&S®TS8960
- ◆ Contains standard test instruments, which can as well be used outside the *Bluetooth*® RF Test System R&S®TS8965
- ◆ Contains the Rohde&Schwarz signaling unit, which can be upgraded to the *Bluetooth*® Protocol Tester R&S®PTW60

- ◆ Uses same well tried software platform and user-friendly GUI as the *Bluetooth*® RF Test System R&S®TS8960
- ◆ Creation of own test scenarios by variation of parameters
- ◆ Automatic generation of detailed test reports
- ◆ Built-in self-test ensures reliability of test results
- ◆ Static calibration tables guarantee defined measurement results

Hardware Components

- ◆ System Controller (R&S®PSL3)
- ◆ *Bluetooth* Signaling Unit R&S®PTW60
- ◆ Spectrum Analyzer R&S®FSP
- ◆ Signal Conditioning Unit R&S®SCU-BT
- ◆ RF Signal Generator R&S®SMIQ03B
- ◆ Microwave Signal Generator R&S®SMR20 or Signal Generator R&S®SML01
- ◆ Power Meter R&S®NRVD



Contents Overview

Chapter Overview

Type Index

R&S Addresses





Contents Overview

Chapter Overview

Type Index

R&S Addresses



Coverage Measurement Systems (Mobile Radio or DAB) – Overview



Successful know-how transfer: innovative ideas for coverage measurements

In the field of radio coverage measurements too, the name of Rohde&Schwarz has over the years become worldwide synonymous with top quality. As the only manufacturer of a complete range of high-performance and practice-oriented system solutions, Rohde&Schwarz is setting standards in this field.

Customer satisfaction is your capital – and your dividends

Our systems are unrivalled regarding fast and high-precision field-strength measurements wherever the location may be, detailed analysis of the receiving conditions for digital radio signals and absolute reliability of the measured data, e.g. through compliance with the Lee criterion. They thus create the basis for interference-free network operation as well as for the economic success of your network. Only a satisfied customer will be a faithful customer too. Therefore your aim should be lasting customer satisfaction which will pay out dividends over and over again.

The optimized network – minimum investment returning maximum performance

Whether in densely built-up areas or in the mountains: the patented interference measurement equipment of Rohde&Schwarz will show you how many base stations are in fact required and where it is best to install them. You benefit two-fold: low investment costs in the network installation phase and maximum reliability in the operational phase. Your customers will appreciate it.

Digital mobile radio systems – a new challenge to measurement technology

Multipath reflection, scatter, diffraction and interference mean a new challenge to every operator in the digital radio network business. Digital mobile radio systems are far more complex than their analog counterparts. Field-strength measurements alone often prove to be inadequate to evaluate the radio coverage in difficult areas. The unique, patented interference measurement system from Rohde&Schwarz analyzes the multipath propaga-

tion of a signal as well as noise or co-channel and adjacent-channel interference – and it detects extraneous signals. There is no potential interference factor whatsoever that is not taken into account. This means that with the measuring systems from Rohde&Schwarz you are always on the safe side and optimally equipped for future digital communication.

Reliable planning through practice-oriented measurement

The dilemma in this context is that only practical experience will furnish useful data about the functioning of a network. This knowledge is required early in the planning phase to optimize the network prior to its commissioning. The solution is in operational measurements using test transmitters. The point of the Rohde&Schwarz solution is that our test transmitters are not only suitable for calibrating the planning software, but can be switched to signalling mode. This allows testing under realistic conditions with exactly the same signals that are later used by the network.



Contents Overview

Chapter Overview

Type Index

R&S Addresses





Contents Overview

Chapter Overview

Type Index

R&S Addresses



Coverage Measurement Systems (Mobile Radio or DAB) – Overview

This stage will show whether the theoretically determined transmitter sites are suitable and the realistic receiving conditions are sound. It's no longer a matter of hope ("will it run smoothly?"). You can put your radio network installed with the aid of Rohde&Schwarz test equipment into operation and be sure that you provide the customer with a fully developed and tested infrastructure.

From a single source

Efforts involved in building up a radio network are enormous: carrying out market

research, procuring the licence, ensuring financing, planning the sites, determining the mobile radio method, choosing the service and sales partners, setting up the administration network, installing the network, testing, optimizing and maintaining it. Therefore it is good to have reliable partners providing competent support in important areas of the implementation and ensuring that the project remains calculable both in time and in money. To live up to all this we supply a complete range of ideally matched measuring systems and components embedded in a consistent software environ-

ment. Whether you decide for budget-priced portable test mobile systems or fully equipped test vehicles, whether you wish to make field-strength measurements or signalling measurements – the solutions offered by us are technically innovative, proven in practice and feature maximum performance and ease of use. Numerous network operators – including all providers of full-coverage digital radio networks in Germany – rely on Rohde&Schwarz systems. Our range of cost-optimized network measurement tools certainly includes the right solution for your specific requirements.

Overview of systems

Type	Designation	Description	Application	Page
R&S®TS9955	High-Performance Coverage Measurement System	High-performance measurement system for all coverage measurements; basic model for CW measurements; can be upgraded for signalling and interference measurements, Measurement Software R&S®ROMES	Field-strength measurement Signalling measurement Interference measurement Network optimization, quality monitoring Network planning and installation	338
R&S®TS9951 Outdoor	Portable Coverage Measurement System	Compact case system with 1 to 4 test mobiles for network-specific measurements as well as network comparison measurements	Signalling measurement Network optimization, quality monitoring Network installation	339
R&S®TS9951 Indoor	Handheld Coverage Measurement System	Special solutions for signalling measurements with 1 or 2 test mobiles	Signalling measurement Network optimization, quality monitoring Network installation	339
R&S®TS9958 ROGER	GSM Interference Analyzer	Quick and easy detection of CO and adjacent channel interferences for mobile applications	Network optimization Quality monitoring	345
R&S®TS9953	Test Transmitter System	System for emitting network-specific digital or CW signals	Signalling measurement Interference measurement Network planning and installation	348
R&S®TS9954 ROSEVAL	Evaluation Software	Evaluation software for all Rohde&Schwarz coverage measurement systems	Field-strength measurement Signalling measurement Data analysis Network optimization Network planning and installation	350
R&S®UMTS PN-Scanner	Drive Test Equipment	PN scanner is embedded in the modular software R&S®ROMES 3. It consists of a dedicated driver, which has to be installed in the basic R&S®ROMES 3 software	Network planning, design Installation, optimization Quality assurance Service	351
R&S®TSMU	Radio Network Analyzer	UMTS PN Scanner Compact System (R&S®TSMU + R&S®TSMU-K1)	UMTS interference analysis and network scanning on 3GPP networks	353



Contents Overview

Chapter Overview

Type Index

R&S Addresses





Contents Overview

Chapter Overview

Type Index

R&S Addresses



Coverage Measurement System R&S®TS9955 (Mobile Radio or DAB/DVB)

Highly accurate and fast coverage measurements in mobile radio or DAB/DVB networks



Brief description

R&S®TS9955 is a high-performance system for measurements carried out in the planning, installation, optimization and quality monitoring of mobile radio or DAB networks. This system is not only suitable for high-precision and fast field-strength measurements, but in an upgraded configuration (see following pages) also for a comprehensive interference analysis which in this unique form is offered by Rohde&Schwarz only.

R&S®TS9955 means an investment in a highly efficient equipment providing extremely fast and reliable measurements. In its basic configuration for field-strength measurements, the system is able to measure four GSM900 channels simultaneously at a speed of up to 90 km/h (63 mph) and with the Lee criterion being adhered to, i.e. a distance of a few centimeters between the measurements. Preparing field-strength profiles and detecting any field-strength gaps is thus speeded up considerably so that accurate data required for calibrating the planning tools are quickly available.

Main features

- ◆ Measurement of field strength; up to four GSM channels at a time at speeds of up to 90 km/h and the LEE criterion being complied with
- ◆ Frequency hopping over 124 channels
- ◆ All filters required for GSM900/1800/1900 and analog systems or DAB
- ◆ Integrated test mobiles for various standards
- ◆ Acquisition of RxQual, RxLev and layer-3 information via test mobile in GSM 900/1800/1900 and GPRS networks
- ◆ Acquisition of signalling data for other mobile communication standards such as ETACS and CDMA
- ◆ Collection of positioning data via GPS (Global Positioning System)
- ◆ Removable hard disk for easy data handling (PC card)
- ◆ Realtime graphics
- ◆ Ten user-definable event keys, various system events with freely definable thresholds
- ◆ User-friendly measurement software for controlling all system components
- ◆ Comprehensive evaluation software

System configuration

The complete measurement equipment can be accommodated in a car. The system installed in the car mainly consists of test receiver, navigation systems, test mobiles, process controller and software. The core of the system is the powerful Test Receiver R&S®ESVD (R&S®ESVB for DAB, DVB-T and CDMA) which is not only extremely fast but also provides maximum level accuracy and frequency stability. Unlike conventional controllers, the robust Coverage Analyzer R&S®PCSP features excellent electromagnetic shielding so that it is absolutely neutral to the highly sensitive measuring equipment.

Software

Measurement Software R&S®ROMES integrates and administrates all system components and is ideally supplemented by the Software Package R&S®TS9954 ROSEVAL (see page 350) for drafting and evaluating the test tours.



Contents Overview

Chapter Overview

Type Index

R&S Addresses





Contents Overview

Chapter Overview

Type Index

R&S Addresses



Coverage Measurement System R&S®TS9951 (Mobile Radio or DAB)

Compact case system with 1 to 4 test mobiles for network-specific measurements and network comparison measurements



Brief description

Out and about with compact systems

System R&S®TS9951 is a budget-priced compact solution for network-specific quality parameter measurements during network installation, but mainly for quality monitoring during regular network operations. Through the integration of the main system components in a robust transit case, the systems are ready for use at any time and easy to transport.

They can optionally be fitted with GSM900/1800/1900 test mobiles, as well as ETACS or CDMA test mobiles.

Simultaneous measurement of different networks to save time

R&S®TS9951 with up to four (maximum of three GSM) test mobiles allow mobiles of different standards to be used at the same time to carry out simultaneous measurements on several networks available at a site, or various antenna models or antenna positions on the vehicle to be tested. The

test mobiles can readily be exchanged in no time. This flexibility is a great advantage in particular for service enterprises that have to carry out measurements on different networks on behalf of their customers often under an enormous pressure of time.

The right system for every application

Different requirements call for different solution

- ◆ R&S®TS9951 for outdoor application with one to four test mobiles for measurements in operational network or for use in conjunction with Test Transmitter System R&S®TS 9953 (GSM technology)
- ◆ R&S®TS9951 for indoor measurements

Main features

- ◆ Compact case system with built-in GPS receiver and with IBM-compatible laptop
- ◆ Test mobiles available for GSM900/1800/1900 CDMA or ETACS
- ◆ One, two, three or four test mobiles
- ◆ Test mobiles (level table storable)
- ◆ Basic measurement in passive idle mode – no call setup required
- ◆ Camp mode for determining the cell boundaries

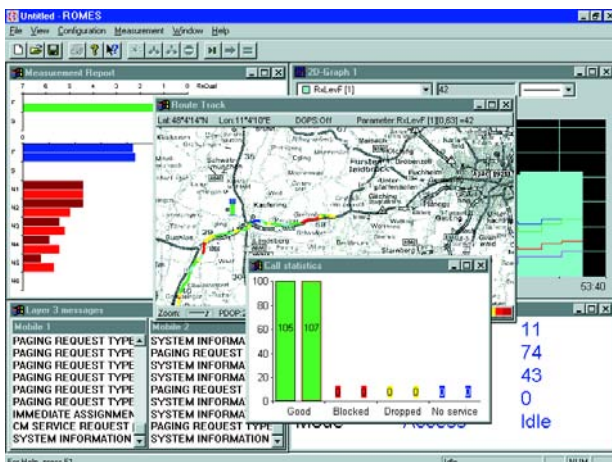

Coverage Measurement Software R&S®ROMES



Contents Overview

Chapter Overview

Type Index

R&S Addresses





Contents Overview

Chapter Overview

Type Index

R&S Addresses



Coverage Measurement System R&S®TS9951 (Mobile Radio or DAB)

- ◆ Recording of signalling and analysis of OSI layer-3 information
- ◆ Realtime graphical display of test report
- ◆ Realtime alphanumeric display for presenting signalling information
- ◆ Realtime presentation of selected parameters on overlaid road maps
- ◆ Automatic or manual measurement mode
- ◆ Outdoor positioning with the aid of GPS navigation
- ◆ GSM Network Quality Analysis (NQA) Software running under Excel 5.0 or 8.0 for statistical evaluation of network availability, quality of connection, time required for call setup, call hold time, etc
- ◆ DC (12 V) or AC supply
- ◆ Indoor navigation modes

System configuration

The systems use the intelligence of the radio telephones, i.e. they automatically find the operating frequencies of the radio service. The measurements are not only carried out in the dedicated mode, but also in the RxQual idle mode of the mobile. The great advantage of these systems is that quality measurements can be made in conjunction with a digital test transmitter such as the R&S®TS9953 (see page 348) so that a full-featured base station is not required.

The test mobiles used are modified by adding vital measurement functions. They also allow measurements on cell boundaries to be readily performed (camp mode). Moreover, the mobiles can be calibrated for high measuring accuracy. The built-in GPS receiver can be supplemented by a Travelpilot or sensor system to handle situations in which GPS reception via satellite is not possible, for instance in road tunnels.

Software

R&S®TS9951 not only features an extraordinary hardware but also a very special software providing far more than the usual capabilities. In addition to the display of standard parameters such as RxQual, RxLev or SSI, this system also allows graphical processing of data and presentation on overlaid road maps.



R&S®TS9951 for indoor measurements

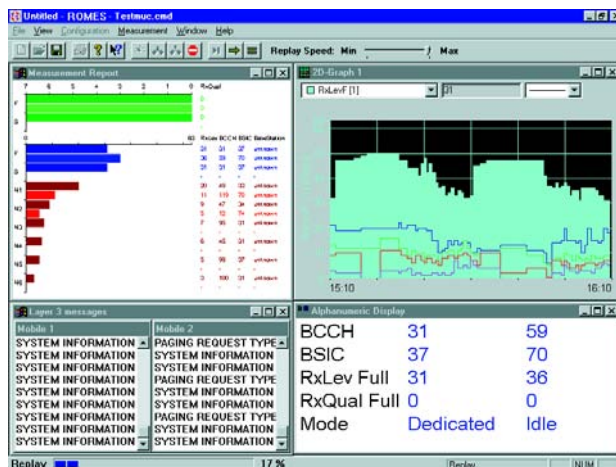

Four typical windows in replay mode

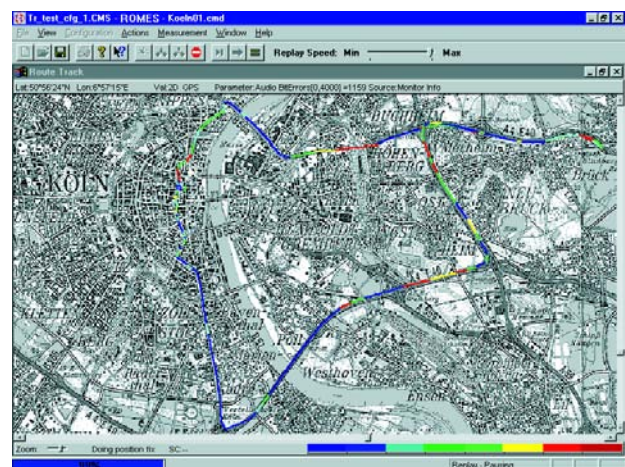

Full-screen display of Route Track window with a complete DAB test tour



Contents Overview

Chapter Overview

Type Index

R&S Addresses





Contents Overview

Chapter Overview

Type Index

R&S Addresses



Test Platform for Mobile Phone Production R&S®TS7100/R&S®TS7180

Scalable solutions from low-cost standard system to turnkey production system

Test System R&S®TS7180



Brief description

The R&S®TS7180 and R&S®TS7100 systems are flexible solutions for mobile phone production tests. The low-cost version R&S®TS7180 satisfies the requirements of most mobile phone production tests. The R&S®TS7100 test platform incorporates a powerful CompactPCI/PXI frame for the integration of a wide variety of additional test and switching modules. This is ideal for contract manufacturers, as it enables them to quickly and flexibly respond to widely differing customer requirements.

The systems can be used immediately or modified and extended to customer requirements. Constructed from standard components, they can be reproduced quickly and at low cost. They are easy to operate and can be smoothly integrated into any production environment.

Main features

- ◆ Versatile applications
 - For all common mobile radio standards
 - For mass production and service
 - For all production steps including PCB tests, functional tests, RF adjustment and final tests covering RF, acoustic, keypad and display functions
 - Multiprotocol and multiband tests with Radio Communication Tester R&S®CMU200
- ◆ Scalable solutions
 - Comprehensive modular test library for immediate use or easy customization
 - Easy upgrade to 3rd generation mobile radios
- Scalable from low-cost platform R&S®TS7180 using industrial PC to modular system platform R&S®TS7100 using CompactPCI/PXI
- ◆ Cost-effective solution
 - Low-cost solution R&S®TS7180 with industrial PC
 - Maximum throughput owing to extremely short measurement times of R&S®CMU200 and real parallel testing using two independent IEC/IEEE bus systems
 - Easy upgrading for upcoming mobile radio standards
 - Test of several mobile radio standards with one R&S®CMU200
 - All hardware and software components based on industry standards



Contents Overview

Chapter Overview

Type Index

R&S Addresses





Test Platform for Mobile Phone Production R&S®TS7100/R&S®TS7180

Putting mobile phones through their paces

The R&S®TS7180 and R&S®TS7100 systems are equally suitable for functional tests on boards, RF calibration of mobile phones or final tests. Each function can be assigned test parameters under menu control. Sub-sequences can also be generated. This hierarchical structure makes it possible to set up even comprehensive test sequences conveniently and with high transparency. Each test step can be assigned result parameters and comparison operations for the conditional execution of actions, thus enabling program branching. At the end of each test run, a test report can automatically be generated from the results, or results can be stored in a database.

Low-cost Production Test System R&S®TS7180

The R&S®TS7180 is a low-cost test system for the mass production of mobile phones. It supports all common mobile radio standards such as GSM, GPRS, CDMA (IS95), TDMA (IS 136), AMPS, cdma2000 and WCDMA as well as tests on terminals with *Bluetooth* capability.

The two-channel version is capable of simultaneously testing two mobile phones. It essentially comprises two Radio Communication Testers R&S®CMU200, two special power supplies and two fixtures. The system is controlled by an industrial PC. The highly compact two-channel system is accommodated in a rack of only 23 HU, thus allowing room for expansions.

Alternatively, a low-profile rack is available. With a height of only 80 cm (13 HU), the complete system can be placed under

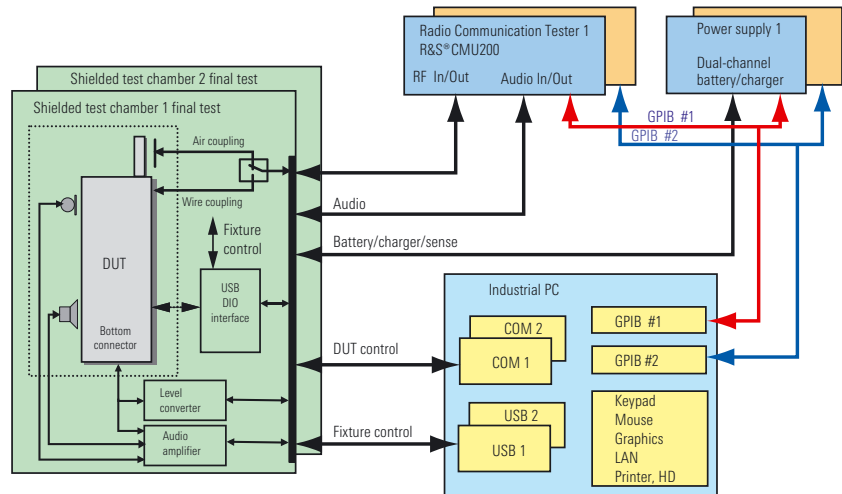

Block diagram R&S®TS7180

the conveyor belt of a production line. It is therefore ideal for subsequent use in fully automatic inline systems.

For manual operation, an extra fixture kit is available that can be extended on a modular basis from a simple PCB test fixture to a complete shielded test fixture for final testing including antenna and acoustic tests. The manual fixture can be used both with the R&S®TS7180 and the R&S®TS7100.

Complete, ready-to-run test sequences make test program generation easy even for users without any programming expertise. The sequences are made up of function calls from the different generic test software libraries (GTSL) and can easily be modified and adapted using the TestStand editor.

GTSL supports all common mobile radio standards and is continually being expanded. User libraries can be added, for example to drive additional devices or the DUT. GTSL also supports all functions relevant in a production test environment

including signal switching, fixture control and RF path compensation. Debugging, data storage and logging are performed by the TestStand test executive from National Instruments. The GTSL software and the TestStand test executive run on both systems.

R&S®TS7100 is the ideal platform for complex test requirements

The R&S®TS7100 test system uses a CompactPCI/PXI frame with an embedded controller (PC) instead of the industrial PC employed by the R&S®TS7180. The remaining hardware components and the system software are identical. The CompactPCI/PXI frame allows for extra functionality by installing additional plug-in boards such as relay modules for path switching, AF generator, AF analyzer, A/B interface (e.g. for cordless telephones), digital multimeter, frame grabber for display tests, etc. The system can thus be adapted to complex test requirements and sequences quickly and flexibly.





Test Platform for Mobile Phone Production R&S®TS7100/R&S®TS7180

R&S®TS7100 features

- ◆ Software-compatible with R&S®TS7180
- ◆ PCB test with expanded AF, DC and digital testing requirements
- ◆ Simultaneous or multiplexed testing of several DUTs (modules) on one panel
- ◆ Multichannel systems comprising 4 channels for example, with 2 channels multiplexed in each case, for minimizing DUT handling times
- ◆ Control and test of additional interfaces
- ◆ Efficient selftest concept

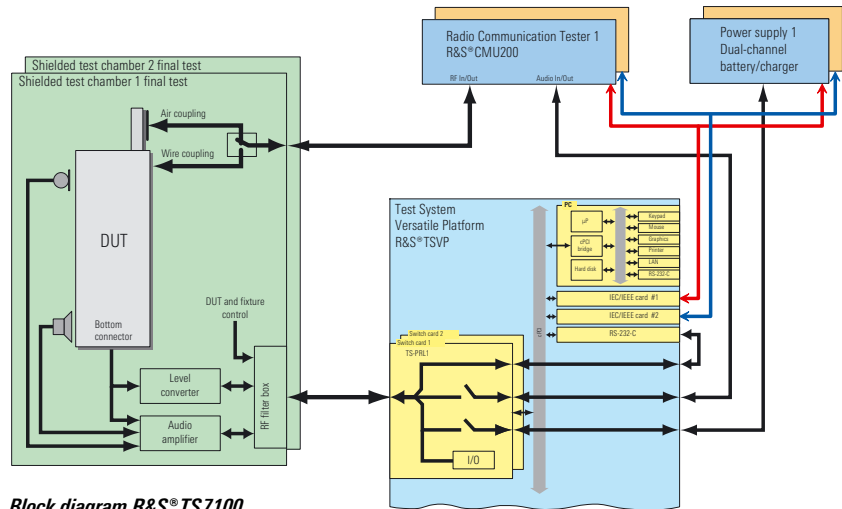

Block diagram R&S®TS7100

CompactPCI/PXI – a compact and flexible standard

The R&S®TS7100 test system incorporates the CompactPCI/PXI system platform R&S®TSVP (Test System Versatile Platform) with a maximum configuration of 31 slots. Within a single unit of 4 HU, this platform accommodates the system controller, relay modules, digital inputs and outputs and test modules in cases where these are not yet provided by the radio communication tester. The universal module R&S®TSPRL1, which offers relay, power relay and digital I/O functionality on a single module, already provides all basic functions required for mobile phone testing, including fixture control. Further measurement functions such as digital multimeters or relay matrix boards can be implemented as required.

The unique wiring concept of the R&S®TSVP makes it possible to route and switch all signals of the various test and stimulus modules entirely within the R&S®TSVP. Thus all signals can be tapped directly at the fixture interface, which allows simpler fixture and interface design. The PXI system architecture, now an industry standard, was developed

from CompactPCI especially for industrial T&M applications. It sets a new standard in flexibility and compactness. A large number of very different PXI modules are already available on the market. CompactPCI boards can also be used.

Parallel test configuration

As in the case of the R&S®TS7180, parallel testing of two mobile phones requires all components (R&S®CMU200, power supply, plug-in boards) to be provided in a dual configuration. The IEC/IEEE bus must also be provided in duplicate to achieve optimal performance. Duplicating the CompactPCI/PXI platform is not necessary due to its high performance. The IEC/IEEE bus devices and the plug-in boards are therefore driven simultaneously in multitasking mode by an embedded system controller under WindowsNT/2000.

Test system software

The software for the R&S®TS7100 and R&S®TS7180 test systems was designed with easy system operation and speedy

test program generation in mind. The user need not have expertise in IEC/IEEE bus programming. C programming and compiling at the test sequence level are also not required. The software is of modular design and comprises a test sequence controller and a comprehensive test case library for mobile phones of different standards.

A wealth of functionality for production testing

The TestStand test executive from National Instruments is used for test sequence control. This software package combines setup and measurement functions to form an executable test sequence and adds all other functions important for the manufacturing process:

- ◆ User administration
- ◆ Execution of several test sequences in multithreading or parallel mode
- ◆ Collection and storage of results
- ◆ Report generation





Contents Overview

Chapter Overview

Type Index

R&S Addresses



Test Platform for Mobile Phone Production R&S®TS7100/R&S®TS7180

Open system architecture for flexible extension

In addition to the large number of libraries supplied with the test system, the customer can create libraries of his own that include typical GTSL features such as multithreading or RF path compensation. For this purpose, example source code for the LabWindows/CVI design environment from National Instruments is provided. Typical applications include DUT control in special test modes, special adjustment routines and the integration of additional system components.

Test programs and fixtures

For mobile phone testing, Rohde&Schwarz also develops test programs and custom test and adjustment functions and supplies test fixtures. Depending on requirements, the fixtures incorporate built-in shielding for acoustic and RF measurements and a mechanical actuator for the keypad test. For RF tests, the fixtures are equipped with special antennas and an RF connection to the test system.

Because of our many years of experience in mobile phone production testing – including with a variety of reference designs from chip set manufacturers – Rohde&Schwarz can offer optimized solutions that cover the entire spectrum from adjustment up to final testing.

Fixture features

- ◆ RF and acoustic shielding
- ◆ Exchangeable DUT mount
- ◆ Simple DUT interfacing
- ◆ USB control, i.e. no extra interface cards needed in PC (only for Windows2000)

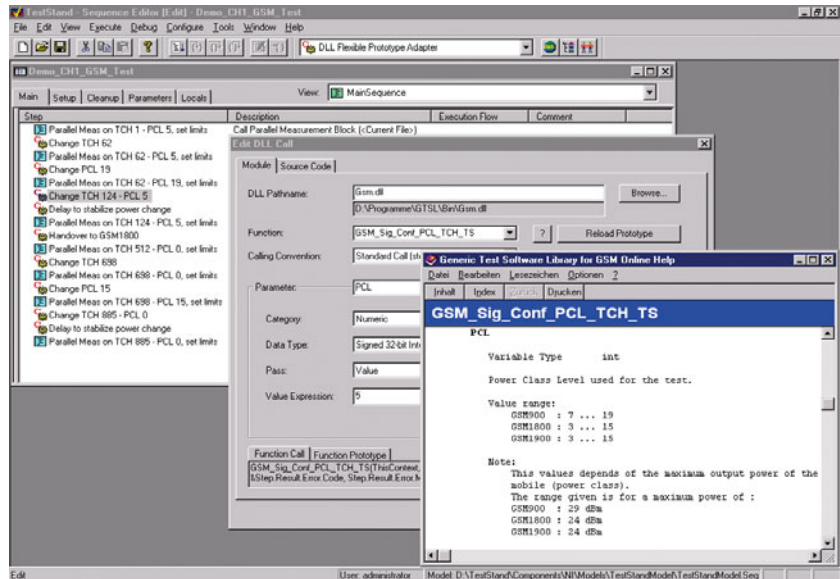

Sequence editor

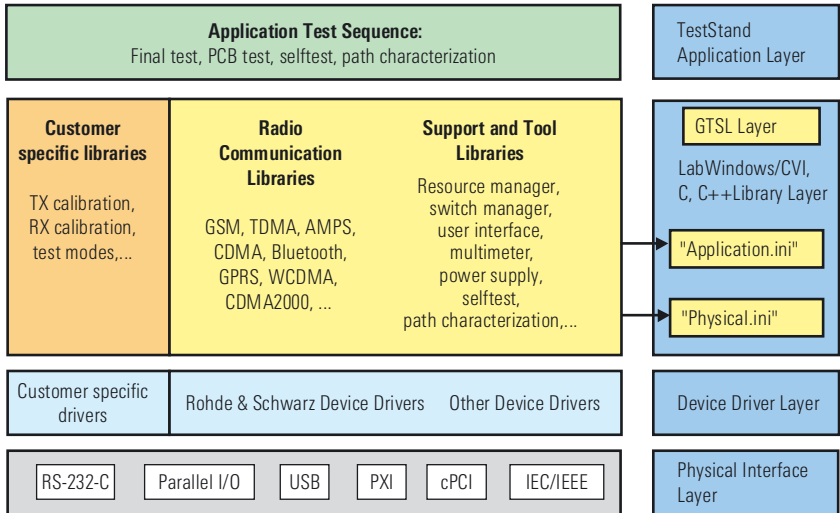

Block diagram GTSL architecture

Customer specific software + Generic Software

- ◆ Fixture interface for R&S®TS7180 and R&S®TS7100
- ◆ Status display for operating personnel
- ◆ Suitable for any RF tests on DUTs
- ◆ Spring contacts
- ◆ Pneumatic control for closing the cover
- ◆ Built-in RF antenna
- ◆ Built-in artificial ear and mouth
- ◆ Pneumatic key actuation
- ◆ Unused feedthroughs for additional signals



Contents Overview

Chapter Overview

Type Index

R&S Addresses





Contents Overview

Chapter Overview

Type Index

R&S Addresses



GSM Interference Analyzer R&S®TS9958 ROGER

Quick and easy detection of CO and adjacent channel interferences for mobile applications



Brief description

The GSM Interference Analyzer R&S®TS9958 is a highly practical solution for co-channel interference measurements that are mobile and fully automatic, making the way for simple analysis.

R&S®ROGER consists of:

- ◆ Test Receiver R&S®TS55-RX
- ◆ up to four test mobiles of different make
- ◆ a GPS receiver
- ◆ a process controller equipped with A/D converter card and signal-processing card

Test Receiver R&S®TS55-RX is accommodated in the controller, making R&S®ROGER a highly compact, lightweight unit. The system uses Coverage Measurement Software R&S®ROMES3, affording a state-of-the-art operating concept and the repeated use of position data sources and mobile-phone linkups. Using an indoor module, the software even allows interference detection inside buildings. R&S®ROGER can optionally be fitted with a position trigger so that it can carry out classic measurement of coverage in addition to interference. In particular the option of extending the system by up to eight additional mobiles of differ-

ent standards (GSM 900/1800, CDMA, GPRS) allows space- and cost-saving performance of different tasks with a single unit.

Main features

- ◆ Fully automatic measurements, no manual control necessary
- ◆ Mobile measurement detects interferences everywhere
- ◆ Easy and simple evaluation of the real source of interference
- ◆ For all GSM/GPRS networks with hopping or non-hopping channels
- ◆ Not only experts can make reliable mobile C/I measurements
- ◆ Quick and reliable graphical evaluation
- ◆ A MUST for GPRS networks due to high data transmission rates
- ◆ Drastic reduction of all measurement costs
- ◆ Significant improvement of fast and reliable results
- ◆ Real interferer identification within seconds

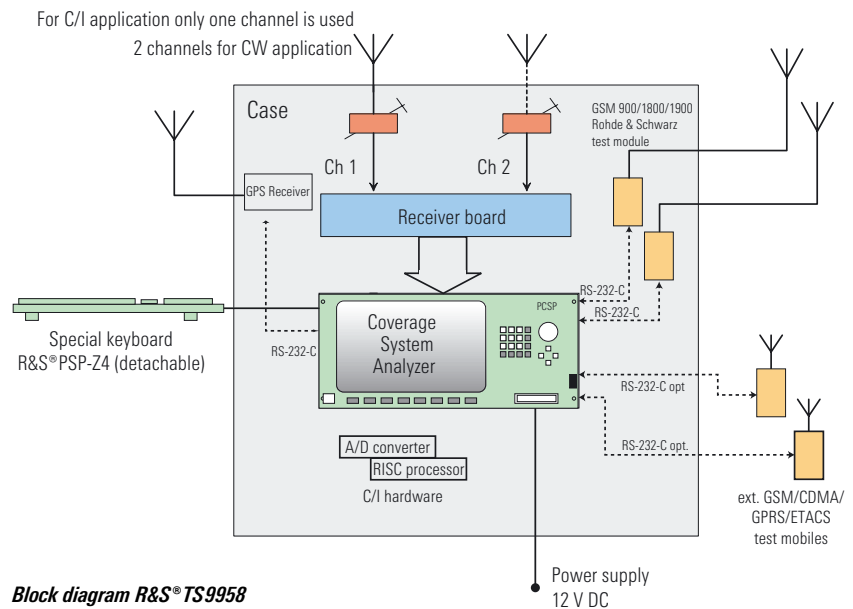

Contents Overview

Chapter Overview

Type Index

R&S Addresses





Contents Overview

Chapter Overview

Type Index

R&S Addresses



GSM Interference Analyzer R&S®TS9958 ROGER

How R&S®ROGER works

Just a short configuration of R&S®ROGER, and the test can start. The test run is automatically controlled by up to four mobile phones, doing away with any manual control. High vehicle speeds are no problem for R&S®ROGER either. Interference measurement is performed in three steps:

- ◆ detection of interference
- ◆ measurement of interfered/interfering signals
- ◆ assignment of these signals to base stations

The signals found can be assigned to the emitting base stations already during the test tour or afterwards on a conventional PC.

Signal display

There are signal displays for two test modes: for C0 (BCCH) and Cx (TCH) measurements. From the disturbed composite signal, R&S®ROGER filters out frequency-correction bursts (FCCHs) for the identification of C0 carriers and displays them. The time axis is structured in lines comparable to a TV frame, arranged such that neighbouring FCCHs of an M51 frame (51 TDMA frames) come vertically one below the other. Because of the idle burst at the end of each M51 frame, a staircase pattern is obtained for each detected C0 carrier. So the graphical presentation of the C0 channel of the serving cell (SC) reveals a staircase with the FCCHs of the SC itself and further patterns in the case of C0 interference. In the analysis window for adjacent channels or TCH channels of the SC, each staircase pattern indicates the presence of C0 interference.

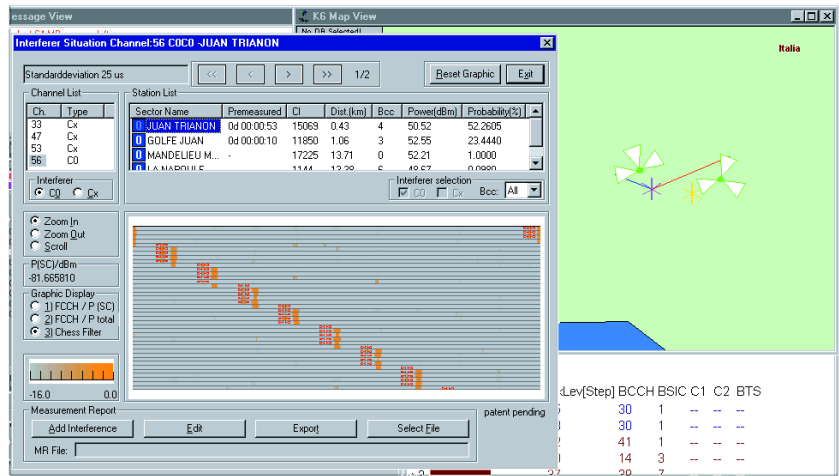

R&S®PCSD-K6 Evaluation Display (here BCCH (C0) with interference from another BCCH (C0))



R&S®PCSD-K6 Evaluation Display (here TCH (Cx) with interference from another TCH (Cx))

In Cx measurement, the composite signal is analyzed in greater detail. Synchronization as well as dummy-burst and training sequences are filtered and visualized grouped according to timeslots. The measured sequences of different base stations are shown in time grids corresponding to two vertical stripes in the Cx display. Different base stations are represented by stripes at different positions along the x axis. Interference can be iden-

tified immediately: from any further stripes displayed next to the two SC stripes. In mobile measurements, the selected signals fluctuate due to fading, reflection and other external influences, resulting in a variety of signal patterns. R&S®ROGER therefore processes interference signals for graphical representation, as the human eye can analyze complex patterns with high reliability.



Contents Overview

Chapter Overview

Type Index

R&S Addresses





Contents Overview

Chapter Overview

Type Index

R&S Addresses



GSM Interference Analyzer R&S®TS9958 ROGER

Fast identification of base stations

To trace interference back to the emitting base station, a feature characteristic of each BTS is used: the expected arrival times of specific signals at the measuring instrument. The times are determined from the measurement position, the expected sending time and the site of the BTS. When a BTS is selected, the expected arrival time is superimposed on the displayed sequences in the form of a template. If this matches a signal measured, the latter can be assigned to the selected BTS. In the case of Cx measurements, the number of possible base stations is reduced by a factor of eight to

those whose base-station colour code and training-sequence code are identical. The selected BTS is additionally shown on a map, allowing comparison of the propagation conditions of server and interferer.

Power measurement

In the interference charts, the power values are colour-coded, allowing a basic evaluation of interference. For purposes of optimization, the measurement system provides the dynamic C/I value for each base station after the SC and interference signals have been selected. The measured and averaged power values can be visualized and if necessary modified.

Modification enables evaluation of the range of interference obtained with mobile measurements. The results of power analysis are stored in a file, and a test report of the analyzed interference signals is generated. The latter may serve as a basis for network modifications.

Specifications in brief

Controller	
Processor	AMD K6, 300 MHz minimum
RAM	32 Mbyte (standard), with PSP-B2 expandible to 64 Mbyte 512 kbyte cache
Hard disk	1.6 Gbyte minimum
Disk drive	1.44 Mbyte, 3½"
Operating system	MS Windows 98/2000/XP
Test & measurement software	LabWindows/CVI
Display	
R&S®PSP2	none
R&S®PSP7	LCD colour, 8.4", screen anti-glare
Resolution with integrated LCD for external monitors	VGA standard: 640 × 480 pixels 1280 × 1024, 1024 × 768, 800 × 600, 640 × 480 pixels, 2 Mbyte video memory
Interfaces	
Internal	ISA, 3 × 16 bits
External	
IEC/IEEE	IEEE488.2, compatible with NI TNT
Serial	2 × RS-232-C
Printer	Centronics LPT1 (ECP, EPP)
PCMCIA	release 2.0, type III, connector
Keyboard, mouse	5-contact DIN, 5-contact PS/2
Interference measurements	
Detection and analysis of C0 and Cx interferences	GSM 900, GSM (DCS) 1800 and GSM (PCS) 1900 networks on the C0 (BCCH), Cx (TCH) and optionally on adjacent channel of the Serving Cell (SC)
Trigger on interferences	automatically or manually based on 1 to 4 GSM test mobiles

Displayed dynamic range		
Type of interference	Total ¹⁾	compared to SC ²⁾
C0 – C0	–16 dB to 0 dB	–13 dB to 3 dB
Cx – C0	–16 dB to 0 dB	–13 dB to 3 dB
Adj – C0	–8 dB to 0 dB	–8 dB to 8 dB
C0 – Cx	–8 dB to 0 dB	–10 dB to 6 dB
Cx – Cx	–8 dB to 0 dB	–10 dB to 6 dB
Adj – Cx	–8 dB to 0 dB	–8 dB to 8 dB

- 1) Compared to the total power in the underlying time slot.
- 2) Compared to an average power level of the SC, measured directly before and after the actual interference.

General data	
Rated temperature range	+5 °C to +45 °C
Operating temperature range	0 °C to +50 °C
AC supply	100 V to 120 V ±10%, 50 Hz to 400 Hz 220 V to 240 V ±10%, 50 Hz to 60 Hz
DC supply	DC, 12 V
Max. power consumption	300 W typ. (12 V DC/25 A)
Dimensions (W × H × D)	500 mm × 200 mm × 800 mm
Weight	19.8 kg

Ordering information

GSM Interference Analyzer R&S®ROGER	R&S®TS9958	1132.2506.02
Options		
Additional, external GSM/GPRS Test Mobiles	on request	



Contents Overview

Chapter Overview

Type Index

R&S Addresses





Contents Overview

Chapter Overview

Type Index

R&S Addresses



GSM Test Transmitter System R&S®TS9953

Ideal positioning of base transceiver stations in frequency and network planning



Brief description

Planning of base transceiver stations

Complex frequency planning tools are used to ensure optimum positioning of a base transceiver station (BTS). The efforts involved, especially for tasks such as obtaining permissions, rental agreements etc, are very high. The GSM network operator therefore needs to be sure that the site calculated is suitable for the BTS installation.

Test Transmitter System R&S®TS9953 fulfils all requirements

- ◆ Unmodulated transmitter:
CW data obtained by means of a test receiver serve as a feedback and for the calibration of frequency planning systems
- ◆ Modulated transmitter:
For measurement tasks in network optimization, a BCCH bit sequence is transmitted by the system as a modulation signal for synchronization with a GSM test mobile. RxLev and RxQual are measured using suitable test mobiles (R&S®TS95XMO, R&S®TS95MMx).

A GSM antenna with appropriate alignment and downtilt is set up on a stable tripod (4 m) or a robust, small mast (5.4 m) on the site determined for a BTS. The

antenna is fed by a 20 W amplifier via an RF cable.

The amplifier is equipped with a GMSK modulator connected ahead of the built-in RF oscillator. A BCCH test sequence stored in the transmitter supplies the modulation signal. The test transmitter simulates a BTS on the downlink.

If the theoretically determined site proves to be unsuitable for a BTS, the test team can simply choose an alternative site since the R&S®TS9953 system is so easy to set up. The data measured on the new site can subsequently be confirmed by the frequency planning department.

Main features

- ◆ Modular transmitter system
- ◆ RF amplifier, CW transmitter (generator, amplifier), GSM test transmitter (modulator, generator, amplifier)
- ◆ Three convenient RF power classes: 2 W, 20 W, 50 W (on request)
- ◆ 2 W GSM test transmitter as exciter for subsequent booster
- ◆ Extremely easy selection of frequency and output power
- ◆ Built-in display for forward and reflected power, and VSWR
- ◆ Rugged cabinet design suitable for transportation

- ◆ Comprehensive useful accessories (weather protection, tripods, antennas, cables, power meter, emergency power supply)

R&S®TS-TX9 and R&S®TS-TX18

For handling measurement tasks within buildings or microcell structures Rohde & Schwarz has developed two very compact test transmitters with 2 W output power. They can be operated via built-in batteries or an external power supply unit. These mini-transmitters are also fitted with a built-in GMSK modulator/oscillator. A suitable BCCH sequence can be loaded via the serial interface. 2 W GMSK transmitters come in two models:

- ◆ R&S®TS-TX9 for GSM900, GSM-R, GSM-E
- ◆ R&S®TS-TX18 for GSM 1800



Mini-transmitter
R&S®TS-TX

A control circuit monitors the set RF power and battery voltage. If a constant RF level cannot be ensured by the supply



Contents Overview

Chapter Overview

Type Index

R&S Addresses



GSM Test Transmitter System R&S®TS9953

voltage, the test transmitter is switched off to prevent erroneous measurements. The 2 W GSMK Transmitter R&S®TS-TX9/ R&S®TS-TX18 can also be used as an exciter for subsequent RF boosters.

R&S®TS9953 for UMTS/WCDMA

To find out about the real propagation conditions in future UMTS/WCDMA networks, a 20 W RF amplifier is available that is ideally suited for the next genera-

tion of mobile radio networks because of its wide frequency band (800 MHz to 2700 MHz). This amplifier can be driven by a generator with WCDMA capability (e.g. R&S®SME03E, R&S®SMIQ) and then supplies a signal that can be measured with conventional coverage measurement systems (e.g. R&S®TS9955).

A suitable converter for the frequency band expansion is available for the Test Receivers R&S®ESVD/ESVB.

BCCH Editing Software R&S®TS53-K1

The R&S®TS53-K1 software allows easy generation of individual BCCH bit sequences. R&S®TS53-K1 runs under Windows 9x, NT or 2000 /XP on a PC, laptop or notebook and can be used for all R&S®TS9953 systems.

The sequence is loaded to the modulators via a serial interface.

Specifications

Frequency range	
R&S®TS-AMPG	935.2 MHz to 959.8 MHz / channels 1 to 124
R&S®TS-AMPD	1805.2 MHz to 1879.8 MHz / channels 512 to 885
R&S®TS-TX9	921 MHz to 959.8 MHz (incl. GSM-R and GSM-E)
R&S®TS-TX18	1805.2 MHz to 1879.8 MHz / channels 512 to 885
Channel spacing	200 kHz
CW mode	unmodulated carrier
GMSK modulation mode	BCCH sequence max. 8 Mbit
Frequency settings	
R&S®TS-AMPG, R&S®TS-AMPD	by means of decade switches
R&S®TS-TX9, R&S®TS-TX18	via softkeys, indication on LCD
Frequency stability	
in operating temperature range	±0.1 ppm
short-term	±5.0 × 10 ⁻¹⁰ /s
long-term	±2.0 × 10 ⁻⁹ /day ±0.5 × 10 ⁻⁶ /year after 30 days of operation
Output power	
R&S®TS-AMPG, R&S®TS-AMPD	43 dBm; ± 1 dB (for 1 dB compression)
R&S®TS-TX9, R&S®TS-TX18	33 dBm; ± 1 dB (for 1 dB compression)
Harmonics suppression	>50 dBc
Nonharmonics suppression	>50 dBc
Overload switchoff	automatic
Service connector for data transfer	9-pin sub-D male
RF connector	
R&S®TS-AMPG, R&S®TS-AMPD, R&S®TS-UMTS	N female for input/output
R&S®TS-TX9, R&S®TS-TX18	SMA connector
UMTS amplifier	
R&S®TS-UMTS	800 MHz to 2700 MHz
Output power	20 W (25 W typ.)
Gain	40 dB (min. ±1.2 dB)
VSWR input	1.8 (max.)

General data

Operating temperature range R&S®TS-AMPG, R&S®TS-AMPD, R&S®TS-UMTS R&S®TS-TX9, R&S®TS-TX18	-10°C to +40°C +5°C to +45°C
Power supply R&S®TS-AMPG, R&S®TS-AMPD, R&S®TS-UMTS R&S®TS-TX9, R&S®TS-TX18	230 V AC (47 Hz to 63 Hz) or 110 V AC 7.2 V battery
Cabinet R&S®TS-UMTS	19"/2 HU/300 mm depth
R&S®TS-AMPG, R&S®TS-AMPD R&S®TS-TX9, R&S®TS-TX18	19"/3 HU/460 mm depth
Dimensions in mm (W × H × D)	84 × 260 × 35
Weight	approx. 700 g

Ordering information

R&S®TS9953 System		
GSM900 Generator Amplifier with internal GMSK Modulator	R&S®TS-AMPG	1070.5689.05
GSM 1800 Generator Amplifier with internal GMSK Modulator	R&S®TS-AMPD	1072.1051.05
GSM900 Transmitter with internal GMSK Modulator	R&S®TS-TX9	1090.8460.02
GSM 1800 Transmitter with internal GMSK Modulator	R&S®TS-TX18	1090.8477.02
Editor Software for generation of BCCH bit sequences on a PC	R&S®TS53-K1	1117.5714.02
UMTS Amplifier	R&S®TS-UMTS	1148.1804.02
Accessories		
Transportation Case, plastic cover for weather protection	R&S®TS-SUIT	1070.5908.04
Transportation Case	R&S®TS-SUIT	1070.5908.02
Transmitting Antenna for GSM900	R&S®HF065D1	4044.1508.02
Transmitting Antenna for GSM 1800	R&S®HF065E1	4043.8509.02
Tripod, 4 m	R&S®TS-MAST	1070.5708.02
Portable Mast, 5.4 m	R&S®TS-MAST	1070.5708.04
7 m Antenna Cable	R&S®TS-CABL	1070.5714.02
Emergency Power Supply	R&S®TS-AGGR	1070.5737.02



Contents Overview

Chapter Overview

Type Index

R&S Addresses



Evaluation Software R&S® ROSEVAL

High-performance evaluation software for field-strength analysis

Brief description

The high-performance Evaluation Software R&S®TS9954 "ROSEVAL" (Rohde & Schwarz evaluation software) is an excellent tool for analyzing all measurement data from data collection systems (Systems R&S®TS9951 or R&S®TS9955) by means of different methods.

With the aid of this software the user can ensure high network quality during the installation, optimization, service and maintenance of his network. As a Windows application it can easily be handled and installed on a standard PC. The concept is modular and adaptable to the most familiar digital networks like GSM, ETACS, CDMA.

As a subunit the well-known GIS software MAPINFO is used for geographical evaluations. The full power of this embedded software is open for designing new customer-specific layers.

Main features

- ◆ Generation of structured meta files
- ◆ Highly effective evaluation through the use of filtered and selected data
- ◆ Efficient file management of measurement data (central server)

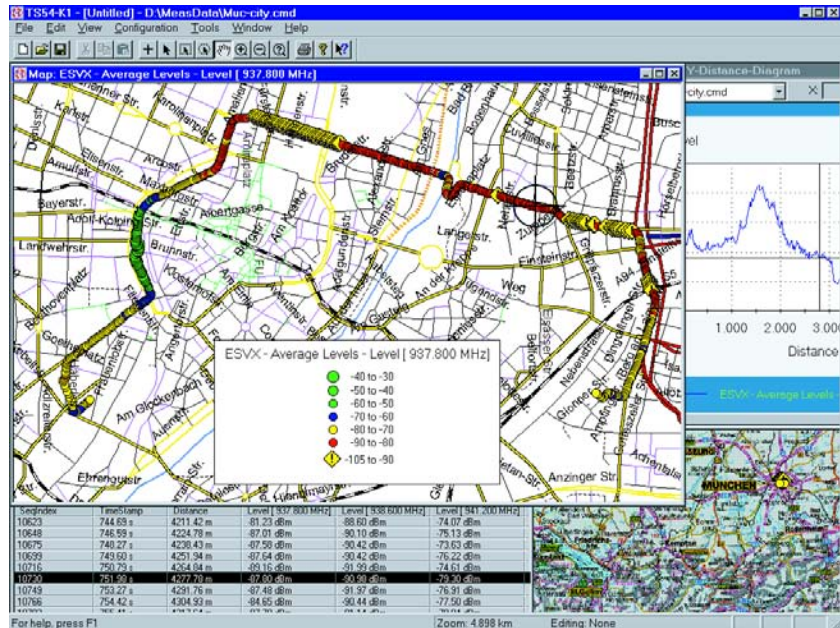

Graphical representation of RxLev and RxQual along a route

- ◆ Fast access to all local temporary data
- ◆ Freely definable legends and comments
- ◆ Selection and evaluation of multiple measurement files in database only limited by system resources
- ◆ Exact reference of measured points to the measurement device they originate from
- ◆ Statistical evaluation and area data mapping
- ◆ Wide range of attributes assignable to each signal (colour, icons, pattern, ranges) to get the most efficient visualization of parameters
- ◆ SQL (structured query language) data selection and evaluation
- ◆ User-definable derived signals
- ◆ Global data selection (interactive and SQL)

- ◆ No special expensive hardware is needed (recommended Pentium class 300 MHz or better)

Available technologies

The most important digital network technologies and Test Receivers R&S®ESVx are supported.

- ◆ CW, Field-Strength Test Receiver R&S®ESVx
- ◆ GSM 900/1800/1900 test mobiles, signalling
- ◆ ETACS test mobile, signalling
- ◆ CDMA test mobile, signalling
- ◆ CIR (channel impulse response) analysis
- ◆ C/I (carrier/interference ratio)



Contents Overview

Chapter Overview

Type Index

R&S Addresses





Contents Overview

Chapter Overview

Type Index

R&S Addresses



R&S®UMTS PN-Scanner

Drive test equipment for network planning, design, installation, optimization, quality assurance and service

Brief description

The PN scanner is embedded in the modular software R&S®ROMES3. It consists of a dedicated driver, which has to be installed in the basic R&S®ROMES 3 software (see data sheet PD 0757.6679).

R&S®ROMES3 is based on a modular system concept, allowing any type of data to be collected and analyzed. Any sensor (e.g. test receiver, test mobile or GPS receiver) capable of result transfer to a PC or Laptop can be used. This opens a wide range of use, from measurements in mobile radio to almost any kind of exotic application. The modular concept enables the implementation of very small systems and high performance systems alike. And it makes the software future-proof, as it can easily be extended to accommodate up coming technologies.

Main features

- ◆ Automatic PN code (node b) detection and analysis
- ◆ Signal strength measurement for different networks (UMTS, GSM, IS95, ...)
- ◆ Full spectrum analyzer function available
- ◆ Coverage measurement software R&S®Romes3 as a modular base
- ◆ Standard Test Receiver R&S®ESPI or Spectrum Analyzer R&S®FSP as RF front end
- ◆ GPS integrated
- ◆ Laptop or system controller application
- ◆ 120 dBm sensitivity



R&S®UMTS PN-scanner can be configured to five packages

Laptop configuration for PN scanning

- ◆ Laptop equipped with PCMCIA IEEE bus interface or LAN interface (recommended)
- ◆ R&S®FSP (spectrum analyzer) or R&S®ESPI (test receiver)
- ◆ GPS system (e.g. Garmin mouse)
- ◆ Measurement software R&S®ROMES3 with PN scanner option

Laptop configuration for CW measurements

- ◆ Laptop equipped with PCMCIA IEEE bus interface or LAN interface
- ◆ R&S®ESPI (test receiver) with preselector
- ◆ GPS system (e.g. Garmin mouse)
- ◆ Measurement software R&S®ROMES3 with PN scanner option

Laptop configuration for CW measurements and PN scanning

- ◆ Laptop equipped with PCMCIA IEEE bus interface or LAN interface
- ◆ R&S®ESPI (test receiver)
- ◆ GPS system (e.g. Garmin mouse)
- ◆ Measurement software R&S®ROMES3 with PN scanner option

Process controller configuration for PN scanning

- ◆ Process Controller R&S®TSPC2 equipped with network interface
- ◆ External 15.1" LC display
- ◆ R&S®FSP (spectrum analyzer) or R&S®ESPI (test receiver)
- ◆ Inertial GPS navigation system
- ◆ Power supply control unit
- ◆ Measurement software R&S®ROMES3 with PN scanner option

High performance system for PN scanning and CW measurement

- ◆ System Process Controller R&S®TSPC2 equipped with network interface
- ◆ External 15.1" LC display
- ◆ R&S®ESPI (test receiver)
- ◆ Inertial GPS navigation system with distance trigger unit and external distance pulse generator
- ◆ Power supply control unit
- ◆ Measurement software R&S®ROMES3 incl. PN scanner and CW option

Software user interface

A core unit is acting as a shunting station. It transfers the data from the external hardware via the driver to the result file and to the displays. In general two differ-



Contents Overview

Chapter Overview

Type Index

R&S Addresses



ent display types are supported, one is the general view e.g. 2 D-chart, alpha or map view, the other is the technical specific view, e.g. GSM measurement report, PN-Scan view etc. In addition post processing of our data with an external tool e.g. Excel is possible. A comfortable, freely definable export function and a lot of specific exports are also available. Upgrading to new hardware is easy. Only a new driver has to be installed by the user.

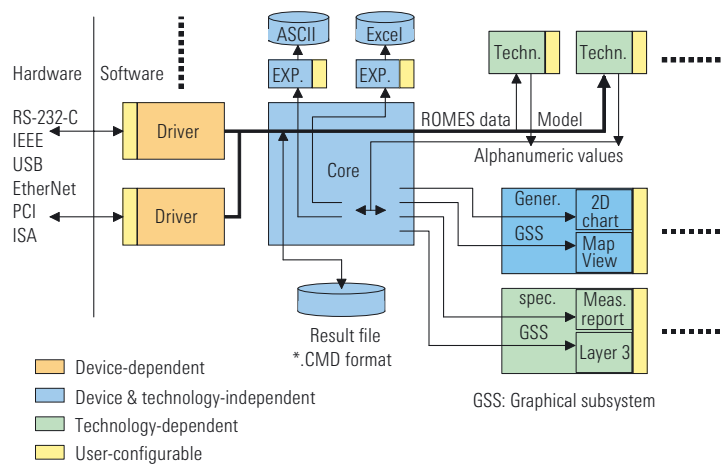

Specifications

General	RSSI of received channel
P-SYNC	Graphical display of correlation result Relative power of detected peaks Time delay of detected peaks
P-CPICH	Code group Scrambling code Total power of CPICH Parameters per scrambling code

Result	Description	Specification
RSCP	Received signal code power	TS 25.215; 5.1.1
SIR	Signal to interference ratio	TS 25.215; 5.1.3
ISCP	Interference signal code power	TS 25.215; 5.1.3
E_c/N_0	The received energy per chip divided by the power density in the band	TS 25.215; 5.1.6
Parameters per identified peak per Scrambling Code		
Power	Power of identified peak	—
Time	Relative time of arrival	—

Code channel power	code channel power of code channels spreading factor
Spectrum	Spectrum of channel Spectrum History of channel

Update rates

Update rates depend on three general aspects:

- ◆ Required measurements
- ◆ Number of node Bs and reflections in the air PC
- ◆ Performance

The following table represents typical update rates on a Pentium III 750 MHz System. The calculations were done with Version ROMES 3.16 and 15 UMTS Slots.

Raw Data	✓	✓	✓	✓	✓	✓
P-SYNC		✓	✓	✓	✓	✓
P-CPICH			✓	✓	✓	✓
Peaks					✓	✓
# Node Bs	—	4	1	4	1	4
Update [s]	0.7	0.9	1.2	1.5	1.4	1,8

Dynamic Ranges

C-PICHs are analyzed successfully up to the following values:

E_c/N_0	-20 dB
RSCP	-100 dBm

Ordering information

Laptop Configuration		
Laptop Computer	R&S®TS951PC	1070.5872.10
IEC625/IEEE-488 PCMCIA type II card	R&S®TS-IEC	1042.0970.02
GPS Navigation System	R&S®TS95GPS	1090.8348.02
EMI Test Receiver ¹⁾	R&S®ESPI3	1142.8007.03
Option preselector for R&S®ESPI ²⁾	R&S®ESPI-B2	1129.7498.02
LAN Interface 10/100 BaseT for R&S®FSP/ESPI	R&S®FSP-B16	1129.8042.02
OCXO 10 MHz for R&S®FSP/ESPI	R&S®FSP-B4	1129.6740.02
Power Supply 12 V DC	R&S®TS-HW	1042.5771.02
Documentation of Calibration Values	R&S®DCV-2	0240.2193.09
Trigger for Coverage Measurements with R&S®FSP/ESPI3	R&S®ESPI-K50	1106.4386.02
CW Driver for R&S®ESPI	R&S®TS5K10E	1143.8198.02
Synchronization Unit for R&S®UMTS PN Scanner	R&S®TS-PNSY	1114.4817.00
R&S®ROMES3 R&S®UMTS PN Scanner Software Driver for UMTS	R&S®TS5-C50C	1063.0579.02
Basic Measurement Software R&S®ROMES3	R&S®TS5K00	1143.7991.02
Evaluation Software ROSEVAL	R&S®TS54-K1	1117.5495.02
UMTS High Performance System		
System Controller, LC-Display and Interfaces System Process Controller	R&S®TSPC2	4049.9571.00
High-performance GPIB Interface	R&S®TS-IEC	1042.1276.02
RS-232-C Interface ³⁾	R&S®TS95SER	1029.5871.02
Network Adapter	R&S®TS95NET	1029.7997.02
15.1" TFT-Display	R&S®TS-LCD1	1064.5800.02
19" Rack for R&S®TS9955 (15 HU)	R&S®TS955RA	1053.5590.02
Measurement Cable Set for R&S®TS9955	R&S®TS955KS	1042.9631.02
Hardware Integration into rack for R&S®TS9955	R&S®TS955HI	1053.5603.02
All other options as in the Laptop configuration		

¹⁾ R&S®FSP can replace R&S®ESPI for PN Scan only, no CW use.

²⁾ Factory installation only for R&S®ESPI.

³⁾ For System Process Controller R&S®TSPC2.



Radio Network Analyzer R&S®TSMU

UMTS PN Scanner Compact System (R&S®TSMU + R&S®TSMU-K1)



Brief description

Network installation and optimization work on 3GPP networks requires measurement tools that are increasingly smart, portable and powerful. The R&S®TSMU provides unmatched capabilities for network analysis and optimization.

When used in combination with software option R&S®ROMES-US2, the Radio Network Analyzer R&S®TSMU is a powerful instrument for UMTS interference analysis and network scanning on 3GPP networks.

The system consists of:

- ◆ Radio Network Analyzer R&S®TSMU
- ◆ Network Optimization Software R&S®ROMES
- ◆ Software driver R&S®ROMES-US2 for R&S®TSMU
- ◆ GPS with PPS pulse and/or synchronization unit for triggering (option)
- ◆ PC or notebook/tablet PC with IEEE 1394 interface

The Network Analyzer R&S®TSMU receives selective one UMTS channel, converts it continuously to a digital I/Q signal, prepares it independently of GPS position data and provides the temporary stored data to a FireWire interface.



R&S®TSMU with a powerful notebook, GPS and UMTS test mobile

The unit consists of three main components:

- ◆ High-quality RF frontend
- ◆ Processing unit with a platform FPGA and an embedded Motorola Power PC
- ◆ DC power supply unit

The digital IF data is transferred to the local 64 MB memory of the processing board. A separate and independent process transfers the digital IF data from the memory via an IEEE 1394 interface to the PC. Additional functions on the processor board control the settings of the RF frontend (RF attenuation, IF and RF amplification) evaluate the command frames from the PC and synchronize the time of the IF sampling data to the high precision pulse per second (PPS) signal of a global positioning system (GPS) receiver.

Every time the R&S®TSMU is switched on, the FPGA and the processor read out the configuration and boot code from a flash memory card.

The application firmware is to be loaded from R&S®ROMES via FireWire interface into the R&S®TSMU. To provide the R&S®TSMU with a new firmware version, only a new software driver is required.

Main features

- ◆ Easy, time-saving and high-precision UMTS coverage measurements and network optimization
- ◆ Handy, portable and compact solution (150 mm × 80 mm × 170 mm, 1.5 kg)
- ◆ Indoor/outdoor and autonomous solutions
- ◆ Multiband measurements up to 12 frequencies parallel
- ◆ GPS system with mapped measured values
- ◆ IEEE 1394 (FireWire) high-speed data interface to PC
- ◆ Low power consumption (typ. 8 W)
- ◆ Wide-range power supply 9 V to 18 V DC
- ◆ Standard processor platform, PCs or notebooks with Windows 2000/XP can be used





Contents Overview

Chapter Overview

Type Index

R&S Addresses



Radio Network Analyzer R&S®TSMU

GPS system (option)

A GPS system provides the position data for the measurement equipment or the measurement vehicle via GPS PPS signal. In case of small and portable solutions with notebook or tablet PC mostly a fully satellite supported GPS comes into operation.

GPS R&S®TS-GINA for highest precise measurements

During the measurement tours, e.g. through tunnels, sometimes the satellite signal is not available. Therefore Rohde&Schwarz offers the GPS R&S®TS-GINA for highest precise measurements.

If the satellite signal is missing, the system substitutes missing data dynamically by

- ◆ inertia sensor to recognize speed up, slow down and direction
- ◆ Peiseler pulse generator for the passed distance

Application R&S®TSMU-K1 (option)

The final finish and presentation of the measurement data is performed by the Network Optimization Software R&S®ROMES. The software R&S®TSMU-K1 is an interface between R&S®TSMU and R&S®ROMES. The ROMES bundles run on a powerful PC, e.g. R&S®TSPC2, a notebook or for very compact solutions also on a tablet PC. An operating system Windows2000/XP and a Firewire or an USB interface are recommended.

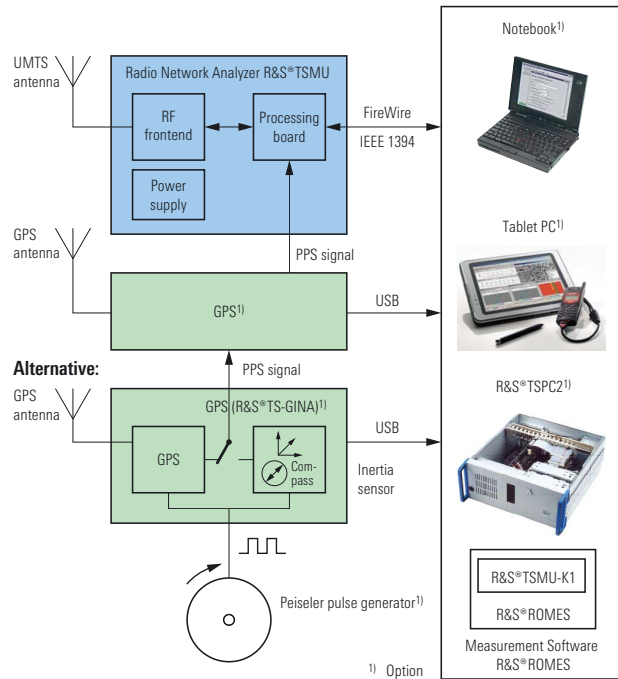

Block diagram of R&S®TSMU system

Specifications in brief

You will find detailed and binding data on the enclosed CD (./DATASHEET/TSMU.pdf), or, for the latest updates, visit www.rohde-schwarz.com, search term: TSMU

Ordering information

Radio Network Analyzer	R&S®TSMU	1153.6000.02
Radio Network Analyzer	R&S®TSMU-H	1153.6000.03
Accessories supplied		
Suitcase CD with handbook, application software		
Documentation „Getting Started“		
UMTS antenna with cable (1.5 m), adapter for UMTS antenna (SME to N, 1.5 m)		
Power supply cable with cigarette lighter connector		
IEEE 1394 cable (2 m)		
Options		
PN Scanner Software Package (includes ROMES Basic, GPS driver, export filter, indoor, NQA and TSMU PN Scanner driver)	R&S®TSMU-K1	1163.3010.02
CW Software Package (includes ROMES Basic, GPS driver, export filter, indoor, NQA and TSMU CW driver)	R&S®TSMU-K2	1163.3010.04
CW Measurement Software Upgrade Package for R&S®ROMES R&S®TSMU-K1	R&S®TSMU-KU2	1163.3010.06
Nokia 6650 UMTS Test Mobile Ext. (option for R&S®TSMU-K1: includes Nokia 6650 test mobile, test firmware, Nokia driver, car kit)	R&S®TSMU-Z10	1163.2995.02
Software Update Contract (for R&S®TSMU-K1 and R&S®TSMU-Z10, valid 1 year)	R&S®TSMU-ZU5	1163.3004.02
230 V AC/12 V DC Power supply	R&S®TSMU-Z1	1166.3786.02
19" Rack Adapter, 2 HU	R&S®TSMU-Z2	1153.6700.02
Extended Documentation of Calibration Values	R&S®DCV-2	0240.2193.15



Contents Overview

Chapter Overview

Type Index

R&S Addresses





Contents Overview

Chapter Overview

Type Index

R&S Addresses



EMC Test Systems

From small systems through to complete equipment of test houses with shielded anechoic chamber and the complete infrastructure required

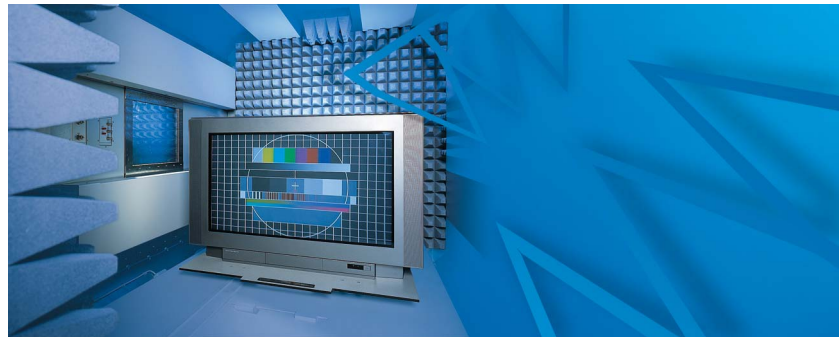

Planning and implementation of practice-oriented EMC test systems requires a great deal of specialized knowledge and experience. This is what Rohde& Schwarz specialists have. All their expertise goes into turnkey EMC test systems which provide the fastest way of yielding correct EMC measurements. These systems are

always tailored to the specific needs of the customer to provide the optimum solution to the tasks on hand. We can offer everything from small systems through to complete equipment of test houses with shielded anechoic chamber and the complete infrastructure required. Naturally, the main emphasis is on fully

automatic measurements with comprehensive documentation of the test results and, if desired, statistical evaluation. One of the important factors of automatic EMC test systems is calibration and continuous monitoring of the measurement accuracy to make sure that all test results will pass another compliance test.

System overview

Type	Description	Application	Special	Page
R&S®TS9970	RF Performance Test System	Measuring main RF parameters of wireless communication equipment under realistic operating conditions	Common RF	356
R&S®TS9975	EMI Test System	EMI measurements of conducted and radiated interference	Commercial, military	358
R&S®TS9976	Emission Test System	EMI and spurious emission measurements on wireless communication equipment during EMC and type approval testing	Conducted, radiated	359
R&S®TS9980	EMI Test System	EMS measurements on sound broadcast and TV receivers, satellite receivers and DVB receivers; automatic and objective picture assessment in susceptibility tests	EN55020 or CISPR20	361
R&S®TS9981	EMS Test System	Measurement of susceptibility to electromagnetic fields	IEC61000-4-3, EN61000-4-3 and other standards	363
R&S®TS9986	EMS Test System	measurement of susceptibility to conducted interference	IEC61000-4-6 and other standards	365
R&S®TS998xM	EUT Monitoring System	Monitoring of the equipment under test for proper functioning during EMS measurements	For R&S®TS9981 and R&S®TS9986	366
R&S®TS9994	EMC Test System	Modular EMC solution for development of car components	Immunity (EMS) 9 kHz to 2.5 GHz, up to 200 V/m, emissions (EMI) 9 kHz to 3 GHz	367
R&S®TS-EMF	Portable System for EMF Measurement	Accurate measurements of electromagnetic fields caused by transmitter systems		368
R&S®EMS-K1	EMS Software	Basis for the automatic control and monitoring of EMS test systems and for the acquisition and analysis of measurement data	Universal EMS software package that can be used for just about any measurement method	370
R&S®EMON-K1	CAN-Bus Monitoring	CAN-bus monitoring when performing EMS measurements with R&S®EMS-K1		372
R&S®EMC32, R&S®EMC32-E+	EMC Software EMI Software	For use in development, for compliance and batch testing For manual and automated EMI measurements		80 82



Contents Overview

Chapter Overview

Type Index

R&S Addresses





Contents Overview

Chapter Overview

Type Index

R&S Addresses



RF Performance Test System R&S®TS9970

RF parameter measurements
on communication equipment

Brief description

Uses

Test System R&S®TS9970 has been designed for measuring main RF parameters of wireless communication equipment under realistic operating conditions. In addition to the spatial radiation characteristic of the communication antenna, receiver parameters such as signal-to-noise ratio and bit error rate as a function of EUT orientation can be determined.

R&S®TS9970 can be effectively used both in design and type approval testing.

Configuration

As shown in block diagram, R&S®TS9970 is made up of the following main components:

- ◆ The communication tester in conjunction with the communication antenna serves for establishing a radio link to the EUT
- ◆ Depending on the type of measurement to be performed, the measurement antenna is connected via a switch matrix either to the spectrum analyzer, RF generator or communication tester

- ◆ The EUT is mounted on a positioning device which is remote-controlled by a controller. An artificial head or body may be used to simulate the operator's influence
- ◆ A central process controller including the appropriate software provides for automatic measurements with documentation of results
- ◆ To simulate open area conditions, a shielded anechoic chamber is required for testing

Main features

- ◆ Determination of spatial radiation and receiving characteristics of EUT
- ◆ Especially suitable for EUTs with integrated antenna
- ◆ Measurement of main RF parameters via air interface
- ◆ Automatic measurements and analysis of results
- ◆ Also available as extension for EMC lab systems

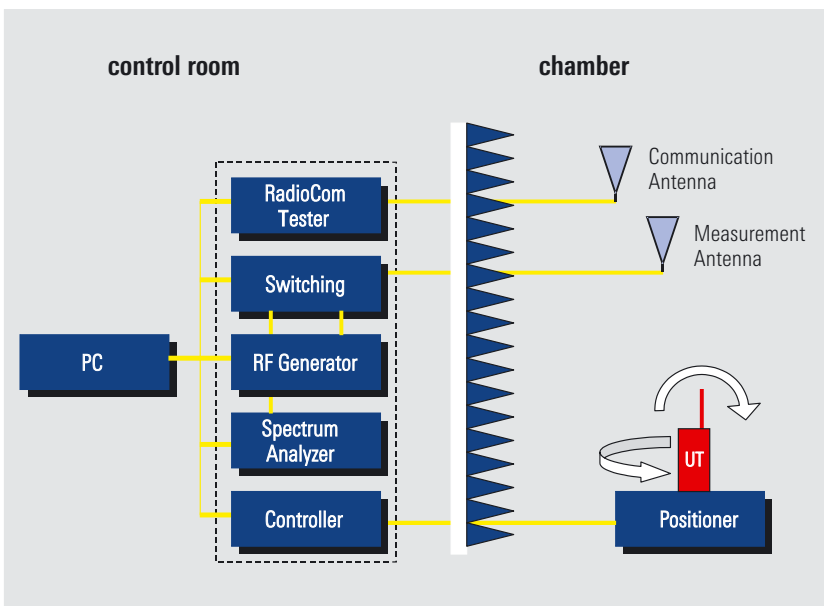

Block diagram R&S®TS9970



Contents Overview

Chapter Overview

Type Index

R&S Addresses





Contents Overview

Chapter Overview

Type Index

R&S Addresses



RF Performance Test System R&S®TS9970

System versions

Version 01 – Basic system

Main components

- ◆ Signal generator
- ◆ Spectrum analyzer
- ◆ Positioning device
- ◆ Communication tester
- ◆ Relay matrix
- ◆ RF attenuator
- ◆ Test and communication antennas
- ◆ System software

Version 02 – Extension for EMV systems

Since existing EMC systems often contain most of the instruments used in the R&S®TS9970 basic system, version 02 is available for extending such systems. Rohde&Schwarz offers an upgrade package tailored to the specific needs.

Standards

Almost any digital and analog radio standard can be implemented in the system. A suitable communication tester is the only prerequisite. Rohde&Schwarz testers support the following standards:

- ◆ TACS, AMPS
- ◆ GSM900/1800/1900
- ◆ DECT
- ◆ CDMA, D-AMPS
- ◆ Bluetooth®
- ◆ GPRS, EDGE
- ◆ UMTS

Implementation of Universal Communication Tester R&S®CMU into the R&S®TS9970 is also possible. Configurations for other standards on request.

Test parameters

- ◆ Bit error rate
- ◆ Effective radiated power (ERP) or equivalent isotropically radiated power (EIRP)
- ◆ Transmission parameters such as RXQUAL, RXLEV, etc
- ◆ S/N ratio at receiver input, etc

System software

Main features

- ◆ Standard test routines for measurement of 3D directional pattern in a spherical or semispherical volume
- ◆ Standard test routines for measurement of 2D directional pattern (azimuth pattern)
- ◆ Setting of all test parameters via the software user interface
- ◆ Automatic evaluation of results (referred to limit values, e.g. conforming to GSM, DECT, etc)
- ◆ Graphical and tabular display of results
- ◆ Automatic generation of test reports
- ◆ Expandable for magnitude and phase measurements (network analyzer)

Specifications

Operating temperature range	+15°C to +40°C
Relative humidity	95% at 40°C
Power supply	110 V AC, 230 V AC
Certification	CE, VDE
The system comes in a 19" rack	

Accessories

Controller	R&S®TS-PCS
Artificial head	R&S®TS-HEA
Artificial body	R&S®TS-BOD



Contents Overview

Chapter Overview

Type Index

R&S Addresses





Contents Overview

Chapter Overview

Type Index

R&S Addresses



EMI Test System R&S®TS9975

EMI measurements of conducted and radiated interference

Brief description

EMI Test System R&S®TS9975 is used for all EMI measurements of conducted and radiated interference.

Commercial standards

- ◆ CISPR 11–22
- ◆ EN 55011–55022
- ◆ VDE 0872–0879
- ◆ ANSI-C63.4
- ◆ FCC 15, 18
- ◆ EACL 1–8

Military standards

- ◆ VG95370–95377
- ◆ DEF-STAN 49–41
- ◆ GAM-EG 13
- ◆ MIL-STD-461/462

Customer-specific adaptations to other standards or different regulations can be integrated into Test System R&S®TS 9975 without any problems.

System configuration

The system features a highly modular hardware and software concept. Customized systems can be configured from a variety of instruments and software options. The system is a complete package of hardware and user-friendly software as well as system services so that the user will be familiar with the system within the shortest possible time.

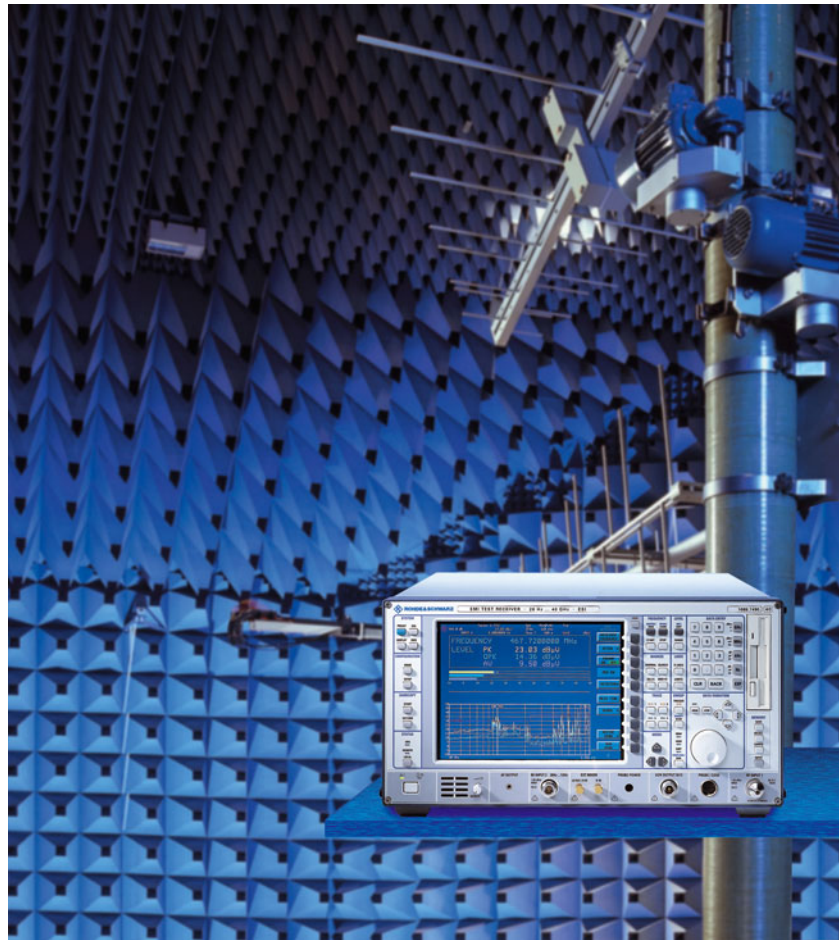

Hardware

A Process Controller (PC) is the core of the system; it controls the complete measurement system via its IEC/IEEE bus interface. Depending on the frequency range to be covered and the special test requirements, measurements are carried out by one or several test receivers.

Hardware expansions

- ◆ Artificial Mains Networks
R&S®ESH2-Z5 and R&S®ENV216
- ◆ System Control Unit R&S®TS-RSP for switching antennas and transducers
- ◆ Rohde&Schwarz test antennas
(i.e. R&S®HL562)

Moreover, Rohde&Schwarz can offer the integration of products from other manufacturers into Test System R&S®TS 9975, if required.

Software concept

EMI Software R&S®EMC32 is used in EMI Test System R&S®TS9975.



Contents Overview

Chapter Overview

Type Index

R&S Addresses





Contents Overview

Chapter Overview

Type Index

R&S Addresses



Emission Test System R&S®TS9976

Fully automatic emission
measurements on wireless
communication equipment

Brief description

Applications

System R&S®TS9976 is used for EMI and spurious emission measurements on wireless communication equipment during EMC and type approval testing. Typical DUTs are mobile phones, base stations, radio sets and short-range devices.

Relevant standards

Measurements of this type are based on the standards and technical regulations published by ETSI (European Telecommunications Standards Institute). For example, EMC measurements on GSM systems are defined by ETS301489-7, measurements of spurious emissions by ETS300-607 (GSM11.10), ETS300-609 (GSM 11.20) and by TBR 5 and 9 (technical basis for regulation). ETS301489-7 provides the generic standard for the EMC of radio equipment.

Specified emission measurements

The above standards stipulate a wide variety of measurements in a very wide frequency range, all of which can be covered with R&S®TS9976:

- ◆ Conducted EMI measurements from 0.15 MHz to 30 MHz in line with EN55022
- ◆ Radiated EMI measurements from 30 MHz to 1000 MHz in line with EN55022
- ◆ Conducted spurious emission measurements from 100 kHz to 12.75 GHz on antenna connector of DUT
- ◆ Radiated spurious emission measurements from 30 MHz to 4 GHz

For some radiocommunication systems (e.g. short-range devices), higher frequency limits (e.g. 40 GHz) are already stipulated for spurious emission measurements. R&S®TS9976 can be modified accordingly to accommodate for this requirement.

Spurious emission measurements differ from EMI measurements to EN55022 mainly in that bandwidths matching the useful signal have to be set on the receiver instead of the typical EMC bandwidths (e.g. 200 Hz, 9 kHz, 120 kHz). It should also be noted that EMC bandwidths are referred to the 6 dB points of the IF filters, whereas the bandwidths for spurious emission measurements are referred to the 3 dB points. In spurious emission measurements, the peak detector takes the place of the quasi-peak detector. All these differences make it necessary that for spurious emission measurements a spectrum analyzer or test receiver with spectrum analyzer functionality be used rather than a pure EMC test receiver. In addition to EMI and spurious emission measurements, R&S®TS9976 can also measure useful signals, for example the EIRP (equivalent isotropically radiated power) of radio sets and modules with integrated antenna.



Contents Overview

Chapter Overview

Type Index

R&S Addresses





Emission Test System R&S®TS9976

Main features

- ◆ Frequency range 0.15 MHz to 18 (40) GHz
- ◆ EMC measurements to IT standards (e.g. EN55022, FCC)
- ◆ Use in type approval testing (e.g. for GSM to ETS300-607/609)
- ◆ Measurement of spurious emissions from radiocommunication equipment

System design

Test receiver

The test receiver forms the core of the system. As a typical EMC test receiver, it evaluates and displays emissions from 0.15 MHz to 1000 MHz in line with EN55022 and, in addition, it offers spectrum analyzer functionality for spurious emission measurements. If only the spurious is to be measured and if precompliance measurements are sufficient for EMC testing, a spectrum analyzer can be used instead of the test receiver.

Anechoic chamber

Radiated emissions are measured in an anechoic chamber. For this, a remote-controlled turntable and an automatic antenna mast with a control unit are required. These components can optionally be supplied with the system and controlled by the system software.

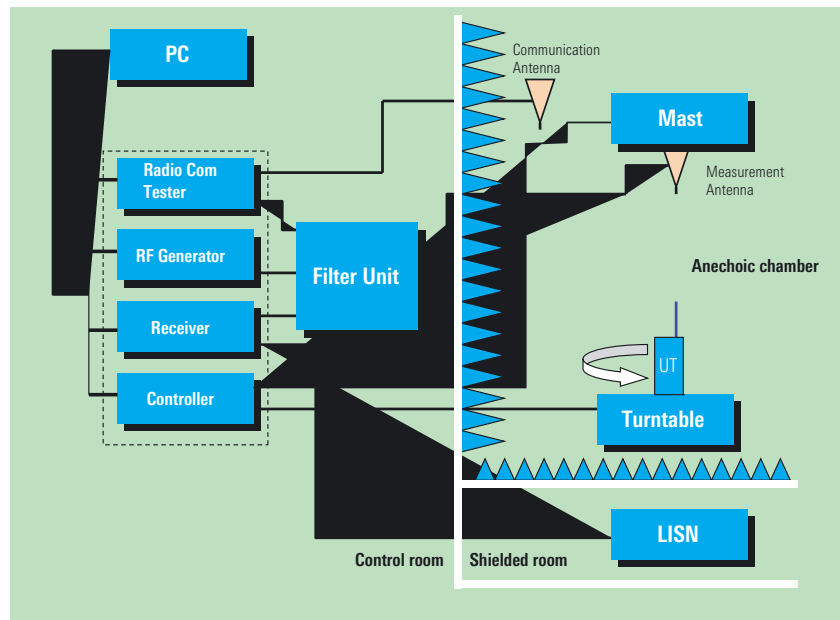

Block diagram R&S®TS9976

Test antennas

Suitable test antennas (usually log-periodic or horn antennas) and artificial mains networks are used for picking up emissions.

Filter unit

To measure spurious emissions, for example of mobile phones, in line with standards at a sufficiently wide dynamic range also with the DUT transmitting, the useful signal emitted by the DUT must be suppressed by means of bandstop or highpass filters.

To this effect, Rohde&Schwarz developed a special filter unit which, thanks to its flexible design, satisfies the common mobile radio standards (GSM900, GSM 1800, DECT, CDMA, etc) and at the same time meets customer-specific requirements.

Communication tester

To switch the DUT to a defined operating state, a communication link has to be set up. This is done by a communication tester integrated in the system.

Signal generator

The signal generator is needed for system calibration and for substitution measurements which are prescribed by some standards.

Controller

The system components are controlled from a PC via the IEC/IEEE bus using EMI Software R&S®ES-K1.

Software

The control software R&S®ES-K1, which forms part of the system, enables fully automatic simple testing. The complete software package runs on a PC or PC-compatible industrial controller. The system components are driven via the IEC/IEEE bus interface.





Contents Overview

Chapter Overview

Type Index

R&S Addresses



EMS Test System Audio and Video R&S®TS9980



EMS measurements on sound and TV broadcast receivers, satellite and DVB receivers

Brief description

The Test System R&S®TS9980 has been designed for automatic measurement of the electromagnetic susceptibility of sound and TV broadcast receivers to EN55020 and CISPR20.

The following measurements are covered:

- ◆ Input immunity (S1)
- ◆ Immunity to conducted voltages (S2a)
- ◆ Immunity to conducted currents (S2b)
- ◆ Immunity to radiated fields (S3)
- ◆ Shielding effectiveness (S4)

As part of ongoing technical development, system solutions for satellite receivers, DVB receivers and set-top boxes have been implemented. Particu-

larly noteworthy is the new TV-MON option for automatic, objective picture assessment of video signals and monitor test pictures (recorded with TV-CAM). The Test System R&S®TS9980 can be used for precompliance measurements, compliance measurements and batch testing.

R&S®TS9980 Audio

The basic system R&S®TS9980 Audio (R&S®TS9980 A) is suitable for testing all analog sound broadcast receivers, tuners, amplifiers, equalizers, CD players, tape decks and accessories. The basic system R&S®TS9980 Audio covers the following broadcast standards:

- ◆ FM: VHF (mono/stereo)
- ◆ AM: LF/MF/HF (mono)

R&S®TS9980 AV Multistandard

The enhanced R&S®TS9980 AV Multistandard System (R&S®TS9980 AV-M) is suitable for all relevant EMS measurements on analog sound and TV broadcast

receivers and video recorders. The following TV standards are covered:

- ◆ PAL: B/G, I, D/K
- ◆ SECAM: D/K, L/L'
- ◆ NTSC: M/N

The relevant audio standards mono, dual sound, NICAM and BTSC (mono) are supported.

R&S®TS9980 DVB Multistandard

The full-featured R&S®TS9980 DVB Multistandard System (R&S®TS9980 DVB-M) is suitable for all relevant EMS measurements on analog and digital sound and TV broadcast receivers, as well as on video recorders and set-top boxes (integrated receiver decoders). In addition to the analog TV standards, the following digital standards are covered:

- ◆ DVB-C QAM (quadrature amplitude modulation) to ETS300429
- ◆ DVB-S QPSK (quadrature phase shift keying) to ETS300421



Contents Overview

Chapter Overview

Type Index

R&S Addresses





Contents Overview

Chapter Overview

Type Index

R&S Addresses



- ◆ DVB-T OFDM (orthogonal frequency division multiplex) to ETS300744
- ◆ ATSC 8VSB (vestigial sideband) to ATSC Doc. A/53

Option R&S®TV-MON

The System Extension R&S®TV-MON allows for the first time fully automatic and objective picture assessment in susceptibility tests on TV receivers and associated equipment, independent of the subjective perception of the viewer. This is a special advantage in the very time-consuming and repetitive procedures required for batch testing and compliance measurements. R&S®TV-MON identifies analog as well as digital picture degradations using objective picture assessment, based on an algorithm-oriented comparison with a reference picture. For equipment under test (EUT) without integrated monitor (e.g. video recorders, set-top boxes), the reference and test pictures at the EUTs video output (CCVS) are used. For EUTs with monitor (e.g. TV sets, monitors) the test pictures are recorded with a video camera system (TV-CAM) available as an option.

System Software R&S®T80-K1

System Software R&S®T80-K1 runs under Windows 9x/NT/2000/XP. The integrated

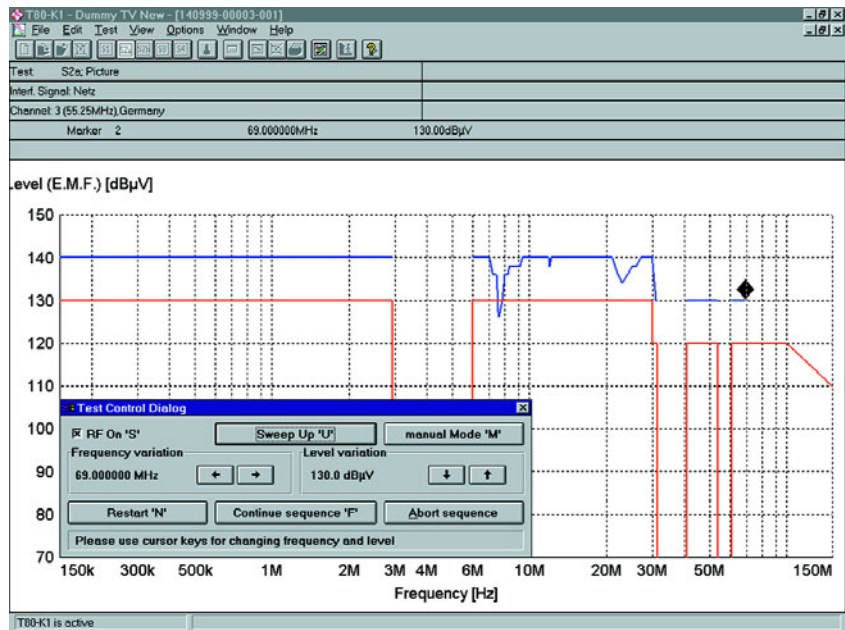

DDE interface allows data exchange between various Windows programs. Each test result is stored together with the test parameters. The test parameters contain all definitions of the test configuration. Due to the joint storage of test results and parameters, any measurement performed can be repeated with exactly the same settings – even a long time afterwards. With the modular options, the software can easily be upgraded to meet future requirements.

The software packages are protected by passwords and various user levels.

DVD Compendium Professional R&S®TestDVD

In many cases, measurement quality is determined to a considerable extent by the scope and quality of the available test signals. The DVD compendium offers a unique compilation of many different video and audio streams for professional applications (see page 140).

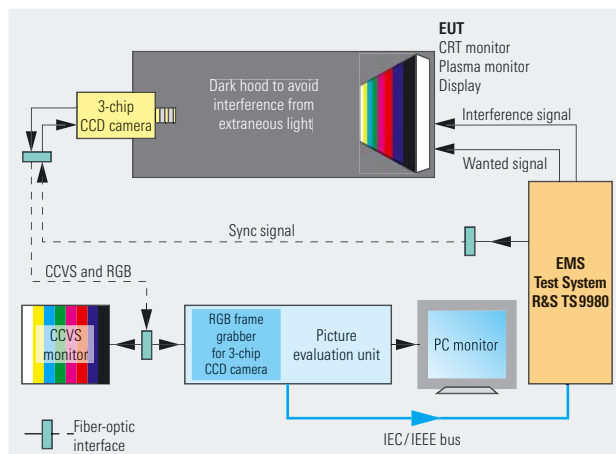

Principle of objective picture quality assessment of TV receivers using R&S®TV-MON and R&S®TV-CAM

Software options

R&S®T80-K4A (option for R&S®TV-MON)

Control software for R&S®TV-MON for objective picture assessment of analog EUTs.

R&S®T80-K4D (option for R&S®TV-MON)

Control software for R&S®TV-MON for objective picture assessment of analog and digital EUTs.

R&S®T80-K5 (video upgrade)

Upgrade for EMS testing of analog TV broadcast receivers and video recorders.

R&S®T80-K6 (audio upgrade)

Upgrade for EMS testing of sound broadcast receivers.

R&S®T80-K7 (DVB upgrade)

Upgrade for EMS testing of satellite and DVB/ATSC TV broadcast receivers.

R&S®T80-K13 (option S4)

Measurement of shielding effectiveness of sound and TV broadcast receivers.



Contents Overview

Chapter Overview

Type Index

R&S Addresses





Contents Overview

Chapter Overview

Type Index

R&S Addresses



EMS Test System R&S®TS9981

EMS measurements to

IEC61000-4-3/EN61000-4-3

Brief description

With the European standards for electromagnetic compatibility and the relevant national EMC laws that came into effect, EMS tests on electrical and electronic equipment are required in all areas of the civilian sector.

The test procedure for determining susceptibility to electromagnetic fields is described in the international standard IEC61000-4-3. In Germany, standard VDE0843, Part 3 was derived from this standard. Product-specific European standards (EN61000-4-3) based on valid national and international standards have been established. Test System R&S®TS9981 is for automatic EMS testing to IEC61000-4-3 and EN61000-4-3 with field strengths of ≥ 10 V/m in the frequency range 80 MHz to 2.5 GHz. On demand the frequency range is expandable up to 3 GHz, 18 GHz or 40 GHz. Hereby an efficient, flexible and reliable tool both for tests in development and acceptance tests is available.



Main features

Automatic measurement of susceptibility to electromagnetic fields to IEC61000-4-3, EN61000-4-3 and other standards

- ◆ Measurements at all severity levels with test field strengths ≥ 10 V/m
- ◆ High accuracy and reproducibility of results
- ◆ Short preparation and test times with powerful software under Windows9x/NT4.0/2000/XP
- ◆ Automatic generation of detailed test reports
- ◆ Efficient test routines
- ◆ User-friendly operation

System configuration

System R&S®TS9981 includes an EMS control unit, an amplifier, a transmitting antenna and a field probe. The system is fully computer-controlled (PC). This makes for reproducible and largely automatic test sequences.

The EMS control unit comprises a signal generator, a field strength meter, a power meter, and a directional coupler unit. The broadband power amplifier used in the system covers the whole frequency range from 80 MHz to 2.5 GHz.

To generate electromagnetic fields, Log-Periodic Antenna R&S®HL046E is used for the frequency range from 80 MHz to 2.5 GHz. EMS tests can be performed without changing the antenna, thus avoiding time-consuming interruptions.



Contents Overview

Chapter Overview

Type Index

R&S Addresses





Contents Overview

Chapter Overview

Type Index

R&S Addresses



EMS Test System R&S®TS9981

Software

Test System R&S®TS9981 comes with the System Software R&S®EMC32 for Windows (see chapter 2, page 80). The software makes it possible to carry out automatic EMS measurements to all relevant standards. R&S®EMC32 is a convenient, cost-effective and reliable tool, enabling fast and easy system operation and high throughput. The extended test and configuration capabilities ensure high reproducibility of results.

Expandability

Test System R&S®TS9981 is of modular design and can be extended by options. Various configuration levels allow for further automation of the test system, so giving an even higher throughput.

Optional components include

- ◆ EUT Monitoring System
R&S®TS9981M (see page 366)
- ◆ Components and accessories for remote-controlled amplifier in separate room
- ◆ Shielded anechoic chambers
- ◆ TEM/GTEM cells

Overview of models

Model	Main applications	Technical features
R&S®TS9981A	Favourably priced test system for development labs, EMC labs and test houses; compliance tests with field strengths according to selected amplifier output power	Generator R&S®SML03, Power Meter R&S®NRVS for measurement of forward power; EMS control unit designed as a 19" desktop; amplifier power depends on desired field strength
R&S®TS9981B	Expandable test system for EMC labs (quality management) and test houses	Same as R&S®TS9981A, but with EMS control unit designed as a 19" rack; measurement of forward and reflected power with R&S®NRVD

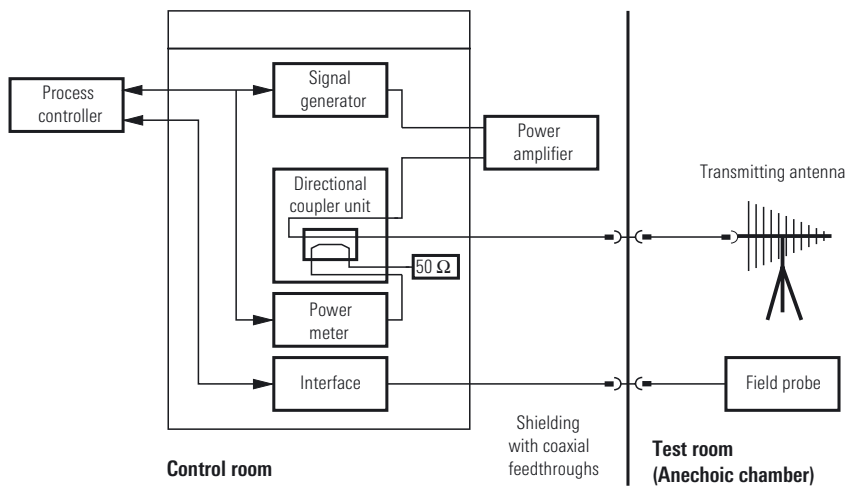

Block diagram R&S®TS9981



Contents Overview

Chapter Overview

Type Index

R&S Addresses





Contents Overview

Chapter Overview

Type Index

R&S Addresses



EMS Test System R&S®TS9986

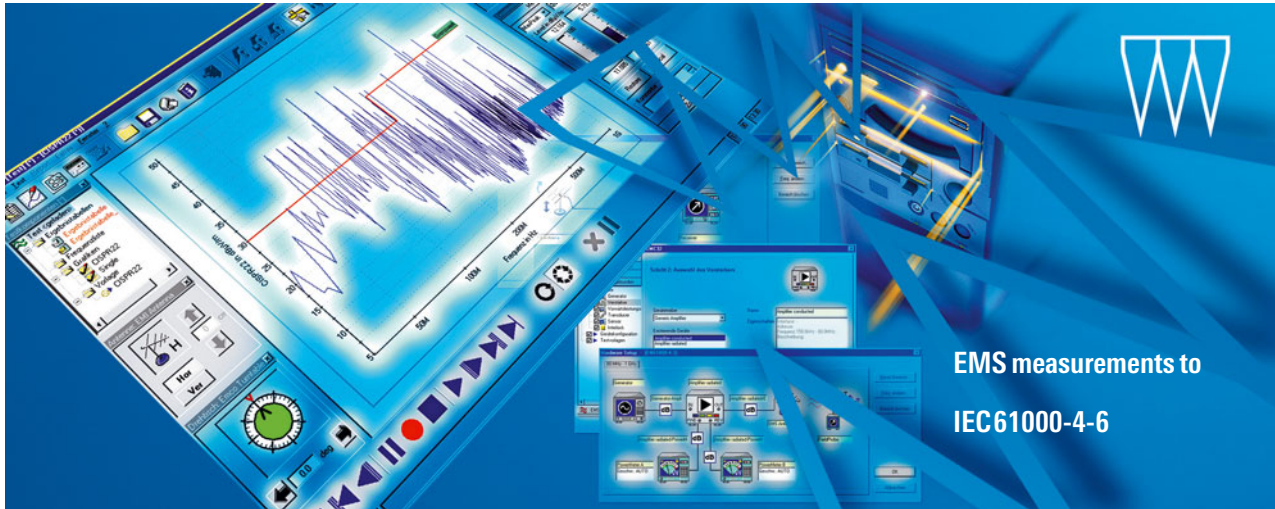

Brief description

With the new European standards for electromagnetic compatibility and the relevant national EMC laws that came into effect, EMS tests on electrical and electronic equipment are required in all areas of the civilian sector. The test procedure for determining susceptibility to conducted RFI is described in the international standard IEC61000-4-6. In Europe, a corresponding EN standard was derived from this standard (EN61000-4-6).

Test System R&S®TS9986 enables automatic EMS testing to IEC61000-4-6 with severity levels of up to 10 V in the extended frequency range 150 kHz to 230 MHz. It is an efficient and reliable tool both for tests in development and acceptance tests.

Main features

- ◆ Automatic measurement of susceptibility to conducted interference to IEC61000-4-6 and other standards
- ◆ High accuracy and reproducibility of results

- ◆ Short preparation and test times with powerful software under Windows
- ◆ Efficient test routines
- ◆ Automatic generation of detailed test reports
- ◆ User-friendly operation

System configuration

System R&S®TS9986 includes a signal generator, a power amplifier and a power meter. The system is fully computer-controlled (PC) via the IEC/IEEE bus. This makes for reproducible and largely automatic test routines.

Software

Test System R&S®TS9986 comes with the System Software R&S® EMC32 for Windows (see chapter 2, page 80). The software makes it possible to carry out automatic EMS measurements to all relevant standards. R&S® EMC32 is a convenient, cost-effective and reliable tool, enabling fast and easy system operation and high throughput. The extended test and configuration capabilities ensure high reproducibility of results.

Expandability

Test System R&S®TS9986 comes in different configuration stages plus an option for automatic EUT monitoring. One or several different coupling/decoupling networks may be required in addition to the R&S®TS9986 basic system configuration depending on the type and number of connections to the EUT. Further accessories including a computer desk, a wooden test bench with a copper surface, and feedthroughs for shielded walls are available to yield a system tailor-made to customer's requirements.

EMS Test System R&S®TS9982

EMS measurements to IEC61000-4-3/6

This system is a combination of Test Systems R&S®TS9981 and R&S®TS9986, allowing EMS measurements in line with IEC61000-4-3 and IEC61000-4-6. It is a favourably priced alternative for users performing measurements in line with both standards.



Contents Overview

Chapter Overview

Type Index

R&S Addresses





Contents Overview

Chapter Overview

Type Index

R&S Addresses



EUT Monitoring Systems R&S®TS998xM

EUT monitoring for Test Systems

R&S®TS9981 and R&S®TS9986

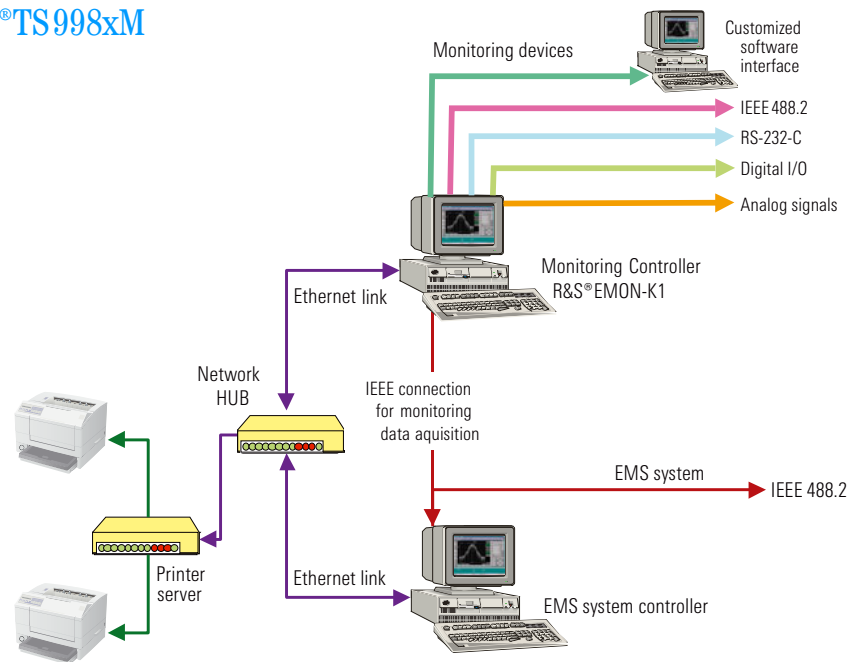

Brief description

EUT (Equipment under Test) Monitoring System R&S®TS998xM is used for automatic monitoring of the equipment under test for proper functioning during EMS measurements. If the EUT does not function properly during the measurement, the field strength is reduced until the EUT resumes correct operation. The field strength is then increased until the EUT shows signs of malfunctioning or the nominal field strength is reached.

System configuration

The above block diagram shows an example of the system functionality. The EUT monitoring system is an option for the EMS test system.

- ◆ Various interfaces are available for evaluating and stimulating the EUT
 - Digital I/O signals
 - Analog signals
 - A/D inputs
 - Output of frequency-proportional voltage

- ◆ Various interfaces for driving measuring instruments
 - IEEE488.2
 - TCP/IP
 - USB
 - RS-232-C
- ◆ Large number of drivers available, e.g.
 - DMMs
 - Oscilloscopes
 - Spectrum analyzers
 - Communication testers
 - Signal generators
 - Power meters
- ◆ Simple driving of other devices, including customer-specific devices, via generic drivers
- ◆ Monitoring and stimulation of complex EUTs via software interface. Existing programs can be included in the monitoring program by integrating a communication routine in the customer software
- ◆ Visual monitoring via video capture system. In addition to the storage of images, this system allows automatic monitoring of analog and digital displays in the case of EUT malfunctioning

Solutions for other special monitoring applications (e.g. CAN bus monitoring, see page 372) are available.

Software concept

Three different concepts are used for monitoring:

- ◆ Direct control of the devices with recording of any number of independent channels
- ◆ Use of an independent controller communicating with the EMS measurement software
- ◆ Device control via R&S®EMON-K1 or R&S®EMC32-S on the system controller or on a separate monitoring controller with the possibility of frequency-asynchronous or frequency-synchronous measurement

In all these cases optimum protection of the EUT is ensured by the definition of switch-off criteria.



Contents Overview

Chapter Overview

Type Index

R&S Addresses





Contents Overview

Chapter Overview

Type Index

R&S Addresses



EMC Test System R&S®TS9994

**Modular EMC solution for
development of car components**

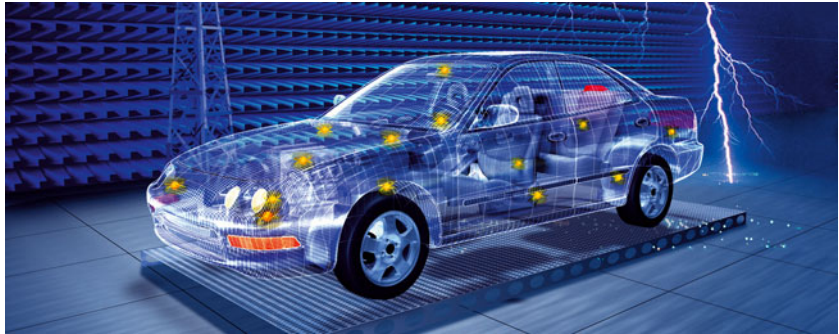

Brief description

Introduction

Due to the increase in electronic subassemblies inside cars, EMC testing is essential for the development of car components. EMC testing throughout the R&D process with compact and local test systems reduces the time to market as well as the risk of subsequent, expensive product modifications.

Main features

- ◆ In line with all relevant automotive standards
- ◆ Modular system design
 - Different modules available
 - Open-ended for future requirements
 - Upgradable to full conformance test system
- ◆ Ideal for R&D laboratories
 - Compact system design
 - No special infrastructure required
- ◆ Immunity (EMS) 9 kHz to 2.5 GHz, up to 200 V/m
- ◆ Emissions (EMI) 9 kHz to 3 GHz
- ◆ Conducted and radiated measurements
- ◆ Covering current and future wireless bands
- ◆ Ready-to-use solution
- ◆ Test Software R&S®EMC32
 - Graphic operating concept (virtual instrument)
 - Intuitive user guidance

Efficiency

The preconfigured and completely tested R&S®TS9994 system in combination with the Rohde&Schwarz installation on site guarantees the customer a ready-to-use EMC system. All necessary system accessories (e.g. for calibration) are included.

This system can be installed where it is most efficient, since it features the following benefits:

- ◆ GTEM cell
- ◆ No need for shielded environment
- ◆ Low acoustic noise of whole test system
- ◆ Compact system design
- ◆ No additional infrastructure required

Training on the system plus the Rohde&Schwarz support including hot-line increase the efficiency and reliability of the system even more.

Applicability

The Test System R&S®TS9994 has been designed to perform measurements in line with the frequency ranges and limits specified in the following standards for car components:

ISO 11452, CISPR25 and SAE J1113.

Due to its modular design, the R&S®TS9994 can be upgraded to a conformance test system at a later stage.

Flexibility

Customers have a choice of different system levels according to their requirements:

Level	Description
1	Radiated emission (EMI) 9 kHz to 3 GHz
2	Emission (EMI) Radiated 9 kHz to 3 GHz Conducted 10 kHz to 108 MHz
3	Radiated susceptibility (EMS) 9 kHz to 1 GHz
4	Susceptibility (EMS) Radiated 9 kHz to 1 GHz Conducted 1 MHz to 400 MHz (BCI)
5	Radiated + conducted EMC Combination of levels 2 and 4
6	Radiated susceptibility (EMS) 1.7 GHz to 2.5 GHz Extension for level 4 or 5

Level 6 is an extension for EMS testing of current and future wireless services (GSM, UMTS, *Bluetooth* etc) in the GHz range.

Easy-to-use Test System Software R&S®EMC32

The intuitive control software, which is an integral part of the system, enables manual and fully automatic testing. For detailed information see page 80.

EUT monitoring

The system provides several alternatives for EUT monitoring applications:

- ◆ Via IEEE/IEC or RS-232-C interface
- ◆ Analog and digital I/O board (NI)
- ◆ Further alternatives on request



Contents Overview

Chapter Overview

Type Index

R&S Addresses





Contents Overview

Chapter Overview

Type Index

R&S Addresses



Portable System for EMF Measurements R&S®TS-EMF



Accurate measurements of electromagnetic fields caused by transmitter systems

Brief description

The Portable System R&S®TS-EMF measures electromagnetic fields in the environment. The measurements are necessary as a basis for discussions about the effects of electromagnetic radiation.



Owing to its wide frequency range from 30 MHz to 3 GHz, the system complies with all common radio services:

- ◆ Mobile radio (GSM, CDMA and UMTS)
- ◆ DECT
- ◆ Bluetooth®
- ◆ WLAN (802.11b)
- ◆ Sound broadcasting
- ◆ TV broadcasting

The frequency-selective measurements determine total emission but also permit assignment to specific radio services. Graphical and numeric result display with reference to a limit value simplifies evaluation.

Main features

Versatile

- ◆ Wide frequency range from 30 MHz to 3 GHz
- ◆ Short-term and long-term measurements
- ◆ Editable measurement packets

Accurate

- ◆ High sensitivity and wide dynamic range

- ◆ Evaluation in compliance with radio services
- ◆ High measurement accuracy

Convenient

- ◆ Isotropic sensor
- ◆ Compact design
- ◆ Preconfigured

Characteristics

The R&S®RFEX system software, which has been specially designed for measuring the effects of electromagnetic fields on the environment (EMCE), provides the user with predefined measurement packets for individual emitters. On site, only the required measurement packets and the measurement mode (single or long-term measurement) need to be selected. Equipped with an isotropic antenna, the measurement system is easy to operate and carries out measurements independently of direction and polarization.

System design

The frequency-selective EMF measurement system consists of the following components:

- ◆ R&S®FSH3, a portable, robust and reliable spectrum analyzer
- ◆ An isotropic sensor for accurate field-strength measurements independent of signal direction and polarization
- ◆ R&S®RFEX, easy-to-operate system software that can be flexibly configured for versatile EMF measurements

One system for various measurements

- ◆ Overview measurement
- ◆ Maximum field strength of an area (also in buildings)
- ◆ Measurement with averaging (referenced to limit values)
- ◆ Long-term measurement (minutes to days)
- ◆ Field-strength characteristic

The requirements of sites and measurement tasks can be met with great flexibility.

Configurable

With the aid of the R&S®RFEX system software, the R&S®TS-EMF can be adapted to special tasks. All main



Contents Overview

Chapter Overview

Type Index

R&S Addresses





Contents Overview

Chapter Overview

Type Index

R&S Addresses



Portable System for EMF Measurements R&S®TS-EMF

parameters, especially the measurement packets, limit values and measurement times, can be defined by the user so that additional radio services and country- and customer-specific requirements can be met.

Accurate measurements

The predefined measurement packets of the R&S®RFEX system software for EMF measurements ensure optimum detection of individual radio services. Faulty measurements due to incorrect settings can thus be avoided particularly when pulsed signals are measured.

Owing to the high sensitivity and wide dynamic range of the system, even low field strengths can be accurately measured and emissions far below the ICNIRP limit can be detected. In addition, accurate measurements can be carried out at extended distances from the base station, the field-strength characteristic can be obtained and "before/after" comparisons (for renovations or expansions) can also be performed.

Compact design

Due to the compact design of the R&S®TS-EMF, mobile and stationary measurements can be performed. The system can be accommodated in the R&S®F3H3 carrying bag (depending on laptop size).

Specifications

Frequency range	30 MHz to 3 GHz isotropic reception due to orthogonally arranged antenna elements that can be electronically switched
Field-strength measurement range	approx. 1 mV/m to 100 V/m ¹)
Sensor connecting cable	2 m (detached sensor operation via long cables possible, see Recommended extras)
Sensor connectors	1 × N, 1 × 9-contact Sub-D (switch)
Tripod adapter	¼-inch thread (for standard tripod)
Power supply, mobile	internal NiMH battery, 4-hour operation; alternatively, external 15 V to 20 V DC
Power supply, AC	100 V to 240 V AC, 50 Hz to 60 Hz
Operating temperature range	0°C to + 50°C
Ambient conditions for sensor	–10°C to +50°C, safety class IP54
Weight	3.5 kg

Requirements for laptop/PC (not part of equipment supplied)	
Operating system	Windows2000, WindowsXP
Hard disk space	min. 4 Mbyte
Display resolution	min. 800 × 600
Interfaces	1 × USB 1 × RS-232-C (alternatively: 2 × USB with USB – RS-232-C converter)
Equipment supplied	– Spectrum Analyzer R&S®F3H3 – Isotropic sensor – EMF Software R&S®RFEX – Converter (for sensor control) – Cable set – Carrying bag for R&S®F3H3

¹⁾ In the case of high field strengths, controller and R&S®F3H3 must be operated in a shielded environment.

Ordering information

Portable System for EMF Measurements	R&S®TS-EMF
Recommended extras	
1 set of sensor cables (8 m)	
Tripod	



Contents Overview

Chapter Overview

Type Index

R&S Addresses





Contents Overview

Chapter Overview

Type Index

R&S Addresses



EMS Software R&S® EMS-K1

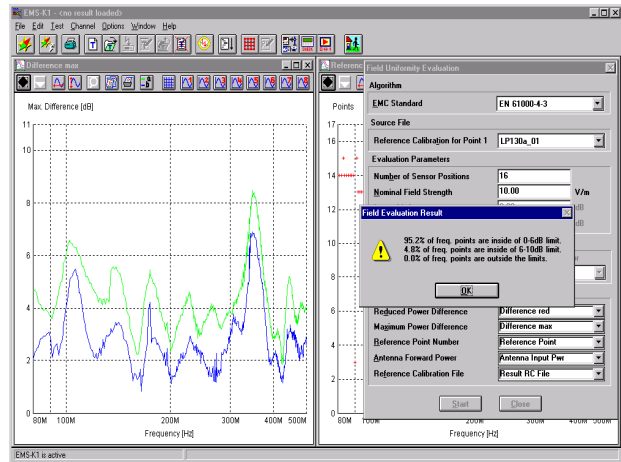
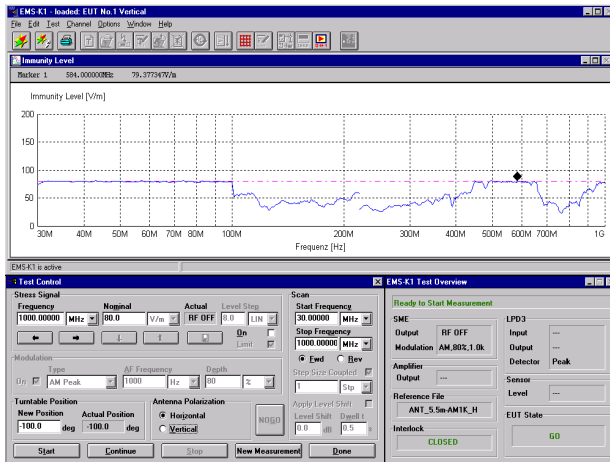

Automatic measurement of electromagnetic susceptibility

Brief description

The powerful Software Package R&S®EMS-K1 forms the basis for the automatic control and monitoring of EMS test systems and also for the acquisition and analysis of the measurement data. The advantages of automation are:

- ◆ high reproducibility and accuracy of results
- ◆ automatic generation of detailed test reports
- ◆ permanent system control
- ◆ automatic calibration and correction of frequency-dependent parameters

The software is extremely user-friendly and has been optimized both for tests in development and acceptance tests. Pre-defined automatic test sequences and procedures as well as high flexibility for easy adaptation to new EMC standards and test methods are further outstanding features.

The basic functions of the R&S®EMS-K1 are:

- ◆ Automatic generation of test signals (field strength, current, voltage)
- ◆ Automatic monitoring of the EUT for malfunctions
- ◆ Determination of the immunity threshold at which an EUT malfunction occurs

The complete software package can be run on a PC or a PC-compatible industrial controller, e.g. Industrial Controller R&S®PSL (see page 376). The measurement devices are controlled via the IEC/IEEE bus using an integrated interface card.

Main features

- ◆ Automatic measurement of electromagnetic susceptibility in line with all commercial and military standards, e.g.
 - EN 61 000-4-3,-6
 - IEC 61000-4-3,6
 - ENV 50140/50141
 - ISO 11451/11452/10600

- VDE 0843
- DIN 40839
- VG 95373, part 10,13
- RTCA/DO-160C
- ◆ Running under Windows 9x/NT/2000/XP
- ◆ Open and modular system software concept
- ◆ High flexibility
- ◆ Programmable user interface
- ◆ Three types of user level:
 - normal
 - advanced
 - system manager
- ◆ Customer-specific test scripts
- ◆ Interface to other Windows programs
- ◆ Supports all EMS test systems from Rohde&Schwarz (R&S®TS 9981/82/83/86)

Automatic generation of immunity parameters

R&S®EMS-K1 is a universal EMS software package that can be used for just about any measurement method and test system:



Contents Overview

Chapter Overview

Type Index

R&S Addresses





Contents Overview

Chapter Overview

Type Index

R&S Addresses



EMS Software R&S®EMS-K1

- ◆ measurement of immunity to radiated electromagnetic fields using an antenna, stripline, TEM or GTEM cell
- ◆ measurement of immunity to conducted interference using coupling/decoupling networks or current clamps
- ◆ measurement of immunity to magnetic fields

Three operating modes are available for setting the immunity level:

- ◆ Transducer: the immunity test level is set by means of a specified transducer correction factor (constant or frequency-dependent) for the amplifier or generator output power
- ◆ Reference calibration: based on calibration data from a reference measurement, the immunity test level is set using the frequency-dependent amplifier power values derived from the calibration measurement
- ◆ Sensor: the test level is set to the required value using the actual level measured with a sensor

EUT monitoring

R&S®EMS-K1 provides logical monitor channels which can handle analog or digital data. A practically unlimited number of channels can be defined; the crucial limiting factor is processor power and the time required for monitoring. Depending on the graphics resolution, any number of channels can be displayed as on-screen diagrams during a measurement. The operator can change the selection of displayed channels while the measurement is running. If there is a NoGo condition, i.e. malfunction of the EUT, a variety of responses can be adopted:

- ◆ store the frequency and the EUT measurement value and continue the measurement automatically
- ◆ stop the program run to enter operator comments or
- ◆ branch to a user application routine, for instance to re-initialize the EUT

It is also possible to combine the above responses in a number of ways. A flexible control concept is implemented in the R&S®EMS-K1 by means of scripts.

Measurement sequence control

The measurement sequence control in R&S®EMS-K1 software is encoded in scripts. The scripts are accessible to the user who can adapt them to his requirements. Scripts provide a high level of flexibility and are easy to modify.

The EMS measurement sequence is implemented by two standard scripts, the qualification mode and the susceptibility mode.

In the qualification mode the selected parameter profile (limits as a function of frequency) is run automatically and the responses of the EUT are recorded. If there is no malfunction detected, the EUT passes the test and fulfills the specified immunity limits. The measurement is thus completed. Only if there is a malfunction is the frequency in question noted automatically.

In the susceptibility mode the immunity threshold is automatically determined when a malfunction occurs. Level and frequency are recorded in the test report; the susceptibility profile of the EUT can then be displayed in the form of graphs or tables.

Ordering information

Basic package		
System Software for EMS test systems R&S®TS9981 (EN 61000-4-3)	R&S®EMS-K14	1084.4296.02
Complete Software Package R&S®EMS-K14/15/16 with additional EUT Monitoring Drivers for EN 61000-4-3, -6	R&S®EMS-K9	1084.3948.02
Extensions		
Standard device driver package for R&S®EMS-K1 for EMS test systems 1 GHz to 18 GHz (e.g. R&S®TS9983), requires Basic Package R&S®EMS-K14	R&S®EMS-K8	1084.3890.00

EUT Monitoring		
Software extension for R&S®EMS-K1		
Basic device driver package for EUT monitoring	R&S®EMS-K20	1084.4196.00
Interface driver for EUT monitoring with external PC	R&S®EMS-K21	1084.4244.02
External EUT Monitoring Software R&S®EMON-K1, with interface driver for R&S®EMS-K1	R&S®EMS-K70	1084.6801.02



Contents Overview

Chapter Overview

Type Index

R&S Addresses





CAN-Bus Monitoring R&S®EMON-K1

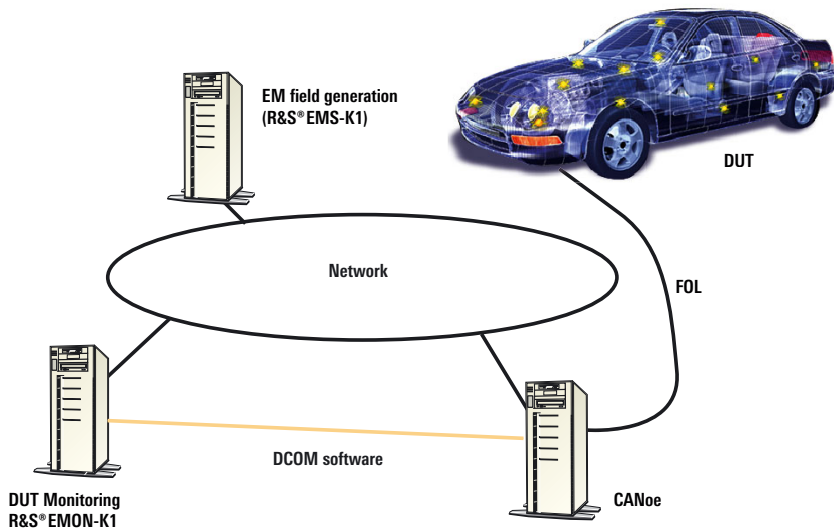

CAN-bus monitoring when performing EMS measurements with R&S®EMS-K1

Main features

- ◆ Runs under WindowsNT4.0
- ◆ Starts and stops measurements in CANoe
- ◆ Measurements:
 - CAN-bus signals
 - Parameters for bus statistics
- ◆ Weights measurement results according to settable criteria, e.g. DUT malfunction yes/no
- ◆ Graphical and tabular display of measurements versus frequency of interfering EM field
- ◆ Sends measured field parameters (frequency, level, antenna polarization) to CANoe and signals DUT failures
- ◆ Starts user-specific actions on the CAN bus
- ◆ Powerful reporting tool
- ◆ Loading of databases in CANoe from R&S®EMON-K1 (as soon as supported by CANoe)

Software requirements

- ◆ CANoe, Vektor Informatik GmbH, as of version 3.0.40
- ◆ R&S®EMON-K1, version 2.0.0
- ◆ R&S®EMS-K1, version 1.20 with option R&S®EMS-K70

Miscellaneous

- ◆ Networked PC or controller operation recommended
- ◆ Software packages R&S®EMON-K1 and CANoe can be installed on the same PC or controller
- ◆ CAN-bus fiber-optic cable extender

