



Product: Handheld Spectrum Analyzer R&S FSH

Testing Mobile Radio Antenna Systems with the R&S[®] FSH

Application Note

This application note describes the procedures used to measure antenna systems for mobile radio base stations using the Handheld Spectrum Analyzer R&S FSH.



Contents

1	Overview	3
2	Antenna Structure	3
3	Measurement Procedures for an Antenna System	5
4	Measuring Antenna Systems.....	6
	Matching Measurements	6
	Matching Measurement of Antenna Systems	6
	Matching Measurement of Antenna Systems with a Tower-Mounted Amplifier (TMA)	6
	Matching Measurement Errors	8
	Discontinuity Measurements	9
	Introduction to DTF and Discontinuity Measurements.....	9
	Discontinuity Measurement on Antenna Systems	12
	Discontinuity Measurement on Antenna Systems with Tower-Mounted Amplifier (TMA).....	12
	Discontinuity Measurement behind the TMA (3G)	13
	Checking the Wavefront Formation of a Stacked Antenna	16
	Special Characteristics of the R&S FSH.....	17
	Measurement of the Transfer function of Active Elements ..	17
	Antenna System Measurements Influenced by RF	17
	Decoupling Measurements.....	19
	Decoupling Measurements of Antenna Systems.....	19
	Decoupling Measurement of Antenna Systems with Tower-Mounted Amplifiers (TMA).....	20
	Measurement of the Tower-Mounted Amplifier (TMA) Gain.....	21
	Measurement of the Whole System Gain.....	21
	TMA Measurement before Installation in the Antenna System..	22
5	Summary of Test Procedures	23
	Antenna Systems without TMA	23
	Antenna Systems with TMA	23
6	Example Measurements	24
	Frequency Ranges.....	24
	Antenna System without Tower-Mounted Amplifier	25
	Matching Measurements	25
	Discontinuity Measurements	26
	Decoupling Measurement	27
	Antenna Systems with Tower-Mounted Amplifier	28
	Matching Measurements	28
	Discontinuity Measurements	29
	Decoupling Measurement	30
	Measurement of the TMA Gain	31
	Measurement of the Whole System Gain.....	32
	Measurement of the TMA Gain at the Base.....	33
7	Additional Information	34
	Note Regarding Defective Antennas	34
	Asymmetry of the Directional Lobe over the Frequency:	34
8	Abbreviations.....	35
9	Ordering Information.....	35

1 Overview

The central components for a mobile radio base station are the antenna system and the site infrastructure. That is not to say that the system technology, the parameterization, and the line connections are not important factors in the quality and availability of a mobile radio site. It is, however, the infrastructure and antenna system that require a large amount of effort to modify. A defective GSM base station or UMTS NodeB could be completely replaced as needed. An antenna system and its site, on the other hand, cannot be so easily replaced.

With respect to the correct functioning of a transmitter system, the transmit and receive characteristics of an antenna system are the weakest link in the chain of equipment that forms the mobile radio network's technical interface to the customer. Moreover, the transmitter system is strongly affected by weather conditions. Electrostatic discharges, as well as snow, rain, and dramatic temperature variations within a short period of time, are very demanding on all materials. The tiniest leaks can flood and destroy cables, filters, or antenna amplifiers within a few rainy weeks. Temperature variations require extreme connection materials with varying thermal expansion coefficients. Any resulting faults, at least during their initial stages, do not generally trigger an automatic fault alarm, and can therefore remain undetected by network operators for a long period of time.

For these reasons, antenna systems require special consideration.

The previously common pure matching measurements performed on antenna systems have decreased in significance since the discovery and implementation of cross-polarized antennas. This type of measurement alone is no longer sufficient to assess the system. Instead, additional measurements, such as decoupling or discontinuity measurements, are now needed. Often, matching measurements do not turn up anything particularly suspicious for cross-polarized antennas in spite of significant defects, if these defects lie in the antenna itself. Only an additional, meaningful measurement of the decoupling of the two systems will uncover possible defects.

This application note addresses basic characteristics of antennas. It discusses the specific measurements for antenna systems and how to interpret these measurement results.

2 Antenna Structure

An antenna is an element that matches electromagnetic energy from the characteristic impedance of the free space (377Ω) to the characteristic impedance of an antenna cable (for example, coaxial cable with 50Ω impedance). Basing on Marconi's discovery that a resonating radiator with $\frac{1}{4}$ of the wavelength of the frequency to be sent or received over ground can work as an antenna, a dipole with two opposing radiators forms the basis for many mobile radio antennas. For mobile radio applications, the diameter of the dipole radiators is large enough to increase the bandwidth of the typically narrowband dipole. Because individual dipoles are operated at their resonant frequency, voltage maxima form at the ends of the dipole elements with voltages that can achieve several thousand volts. Stringent measures must be taken within the antenna system to prevent discharges or ionization of the air at the dipole ends, because these can result in significant mixing products and the associated interference in the receive path of the mobile radio

facility. These in turn can significantly impair the operation of the receive path.

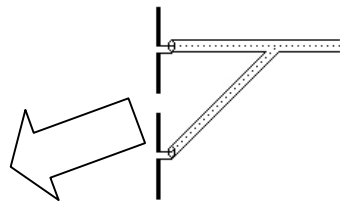
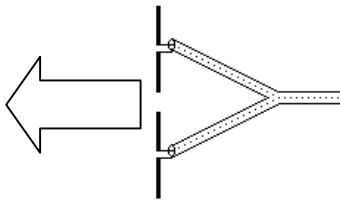

Straight and downtilted dipole configuration

These discharges are even found in incorrectly assembled connections and aged filter modules, especially at 430 MHz. Improperly assembled electrical connections form capacitors and lead to ionization discharges within the connectors due to the transmit power.

An antenna is generally made up of multiple stacked antenna elements (dipoles). These are connected via tuned coaxial lines. The spacing of the dipole fields is set so that a homogenous electromagnetic field forms in the antenna's far field that shows the desired characteristics with respect to gain, downtilt, and aperture. An antenna of this type can be electrically downtilted if the upper dipoles transmit a little sooner than the lower dipoles. "Electrically" means that the upper dipoles must send during a somewhat earlier phase than the lower dipoles.

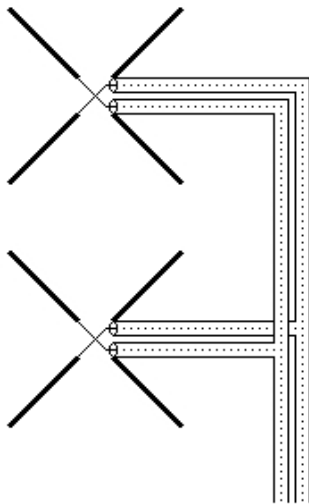

Cross-polarized antenna

A cross-polarized antenna consists of two separate antenna systems that are oriented at 90° to one another. This means that there are two separate antenna systems housed together that replace physically separated antennas. The receive duplex gain is ensured by the polarization planes and is almost as great as the physical separation of the receive antennas. Depending on the wiring, the downlink (DL) contains various channels or radio terminals (RT) on both polarization planes whose influence in the coverage area can be detected but is generally negligible.

The cross-polarized antenna ideally combines the need for vertical polarization of mobile radio networks with the improved propagation permitted by a horizontally polarized wave.

3 Test Methods for an Antenna System

The following measurements can be performed on an antenna system:

- Return loss measurement: This matching measurement for an antenna system provides information about the basic condition of the system. If problems already show up during this test, it can be assumed with a high degree of certainty that the antenna system contains faults that will affect the customer.
- Discontinuity measurement: The measurement of discontinuities in the antenna system shows abnormal changes in the characteristic impedance as well as the location of the discontinuities in the connection and feeder cables and in the cable connectors (plugs and sockets). This measurement makes it possible to determine the effect of these discontinuities on the operating frequency range of the antenna system and to determine the radiation characteristics of the antenna itself.
- Decoupling measurement: The decoupling measurement determines the electrical decoupling of two antenna systems in the coverage area. This type of measurement is both necessary and useful for cross-polarized antennas.

To detect all possible sources of errors and to record the data for a specific antenna system, the above measurements can be carried out as follows on the antenna system:

- Measure the return loss (RL) and the discontinuities (time domain reflection, TDR or frequency domain reflection, FDR) with a connected antenna (= measurement of the complete system). The TDR measurement shows discontinuities in the cable and, if carried out within the operating frequency range of the antenna, it also shows the formation of the antenna field.
- Measure the return loss (RL) and the discontinuities (TDR, FDR) using an open circuit in place of an antenna at the end of the cable. The return loss can be used to determine the cable loss, and the discontinuity measurement shows the end of the cable.
- Measure the return loss (RL) and the discontinuities (TDR, FDR) with a closed cable end. This measurement shows discontinuities, including those that are near the antenna.
- Measure the decoupling of both antenna systems in a cross-polarized antenna setup. This measurement shows the electrical characteristics of these antennas better than a simple return loss measurement.

Measurements of the feeder cable with a disconnected antenna are desirable in theory, but rarely done in practice. Once the facilities have been handed over after completion of the construction work, disconnecting the outside lines can result in a loss of warranty, depending on the terms of the contract. For this reason, the company setting up the antenna system should at least measure the cable loss (open circuit on the end of the feeder cable).

Refer to Section 5 for a summary of the measurements, along with acceptance or assessment tests.

4 Measuring Antenna Systems

Matching Measurements

Matching Measurement of Antenna Systems

Matching or return loss measurement is the traditional method of assessing an antenna system. The amount of the return loss is indicative of the effectiveness with which the antenna radiates the energy supplied to it. The lower the return loss, the more that costly RF energy is being reflected from the antenna and returned back to the transmit output stage. The following happens if too much RF energy is reflected:

- The reflected energy is not radiated from the antenna and is therefore not available for radio transmission.
- The reflected energy is returned to the transmit output stage, resulting in additional warming of the transmit output stage. Extreme mismatching can even damage the transmitter.
- The reflected energy can lead to intermodulation in the transmit output stage.
- In the case of a mismatching, the returning energy interacts with the forward power to cause standing waves in the antenna system. The current or voltage loops caused by the standing wave can lead to impairment (or even damage) in the filter modules, for example.

The better matched an antenna system, the better the energy is radiated. In modern, highly complex antenna systems (stacked, multiband cross-polarized antennas with downtilt mechanisms), there is more to consider than just the matching, however. The energy must exit the antenna directionally, or it must be received by the antenna in receive mode as defined in the technical specifications. Additional (decoupling) measurements are needed to assess these characteristics.

Matching Measurement of Antenna Systems with a Tower-Mounted Amplifier (TMA)

Matching measurement of an antenna system with a tower-mounted amplifier (TMA) is performed essentially the same as without the TMA. Please note that the TMA must remain without current during the measurement so that a bypass present in the TMA will be active. A bypass of this type bypasses the receive amplifier when the TMA is without current. On the one hand, the uplink (UL) is not completely interrupted when the supply voltage fails, and on the other hand, the bypass permits at least the most important measurements to be carried out on antenna systems with TMA.

Testing Antenna Systems Using the R&S FSH

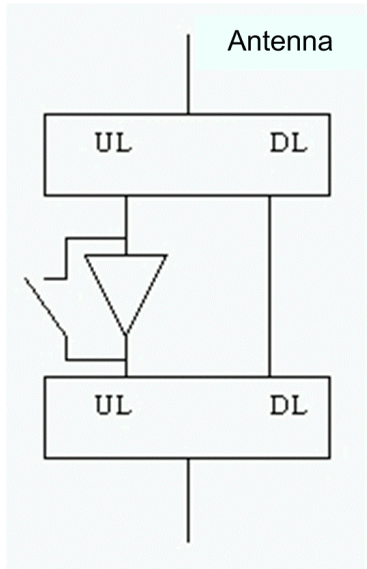

TMA block diagram

When interpreting the measurement results, please remember that the actual antenna matching is visible only in the passbands of the TMA filters. These filters are also looped into the signalling path when the TMA is used in bypass mode.

In the case of a TMA without bypass, the antenna and TMA measurements can be performed only on a very limited basis:

Matching, decoupling, and discontinuity measurements can be performed only in the down link (DL).

The accuracy of the gain measurement on the TMA is not adequate because the decoupling values in the receive path must be compared against the (amplified) values of the transmit path, while the degree of decoupling over the antenna frequency is not known.

This diagram shows the effects of the TMA transmit and receive filters on a matching measurement.

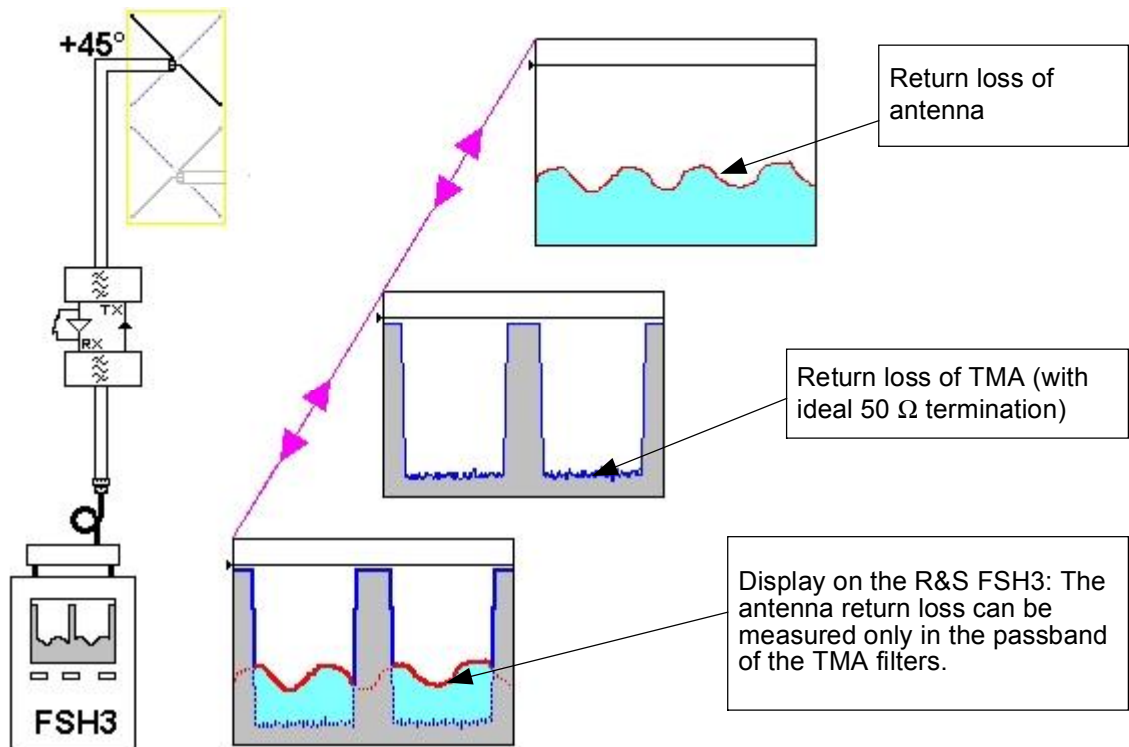

Matching Measurement Errors

The matching measurement determines the return loss for the whole antenna system, including the RF feeder cable and jumper. Because the return loss of the antenna can only rarely be determined directly, it is measured at the base of the antenna system.

As the line attenuation increases, the relationship between the power fed to the antenna and the power reflected back from it is adulterated because the power flowing back and forth must overcome the cable loss. Higher line attenuation appears to result in higher return loss; however, the return loss does not increase in a linear relationship to the line attenuation.

On the other hand, lower cable loss values with increasing mismatching of the antenna result in the measurement of better matching values at the antenna base. This can be explained by standing waves that form in the feeder cable as the mismatching of the antenna increases. These waves disrupt the even distribution of current and voltage in the cable through the formation of current and voltage loops.

The relationship of the various measurement and limit values is described with the following formula based on the transmission theory:

$$a_r = 20 \cdot \lg\left(10^{\frac{a_{rK}}{20}} + 10^{2 \cdot a_K + \frac{a_{rA}}{20}}\right)$$

<i>Return loss at base of the antenna:</i>	a_r
<i>Return loss of cable with 50 W load:</i>	a_{rK}
<i>Cable loss:</i>	a_K
<i>Return loss of antenna:</i>	a_{rA}

The limit values for the antenna are determined in conjunction with the cable loss, the return loss of the antenna cable, and the return loss of the antenna. These limit values are shown in the following table for the various cable losses.

Additional influences, primarily RF discontinuities resulting from multiple cable bends, clamps that are too tight, or mismatching plugs, are not taken into consideration. The assessment must be made based on the discontinuity measurement and a visual onsite check.

Example: An antenna matching of $a_A = 14$ dB (VSWR = 1.5) — measured over a feeder cable loss of 0.3 dB — can indicate an antenna matching value of 12.5 dB during the measurement. (The return loss for the cable is 26 dB in this case.)

Feeder cable loss [dB]	$a_t = 17.7$ dB (VSWR = 1.3)			$a_t = 15.6$ dB (VSWR = 1.4)			$a_t = 14.0$ dB (VSWR = 1.5)		
	Cable return loss [dB]:								
	27	26	25	27	26	25	27	26	25
0.3	15.6	15.3	15.0	14.0	13.8	13.5	12.7	12.5	12.3
0.5	15.9	15.6	15.3	14.3	14.1	13.8	13.1	12.8	12.6
0.7	16.2	15.9	15.5	14.6	14.4	14.1	13.4	13.2	12.9
1.0	16.6	16.3	15.9	15.1	14.8	14.5	13.8	13.6	13.4
1.5	17.3	16.9	16.6	15.8	15.5	15.2	14.6	14.4	14.1
2.0	17.9	17.6	17.2	16.5	16.2	15.9	15.4	15.1	14.8
2.5	18.6	18.2	17.8	17.2	16.9	16.5	16.1	15.8	15.5
3.0	19.2	18.8	18.3	17.9	17.5	17.1	16.8	16.5	16.1
3.5	19.8	19.3	18.8	18.5	18.1	17.7	17.5	17.1	16.8
4.0	20.3	19.8	19.3	19.1	18.7	18.3	18.1	17.8	17.4

Return loss for an antenna system in conjunction with the cable loss

Discontinuity Measurements

Introduction to DTF and Discontinuity Measurements

The traditional measurement of line discontinuities is carried out using a tool such as the pulse reflectometer. This test sends a very short pulse on the line under test. The discontinuities in the cable reflect a portion of the pulse power and so are recorded over time by the reflectometer. Discontinuities lying farther away require a longer time to return the reflection than do faults that are closer.

The development of cost-effective vector network analyzers and the refinement of the mathematical model have pushed the pulse reflectometer out of the market for measurements in coaxial RF systems.

In modern equipment, a discontinuity measurement is based on the result of a matching measurement in the frequency range (frequency domain reflectometer FDR), such as is offered by the R&S FSH. Using a mathematical conversion of the frequency range into the time domain using a Fourier, Chirp-Z, or other mathematical transformation, the time to reach a fault and the fault's amplitude are calculated based on the source signal.

To display the distance to fault (DTF), the transit time for a wave through the cable is converted to an absolute distance using the cable's velocity factor and the velocity of light. The amplitude is corrected by means of a calculation that uses the loss of the cable under test (at the appropriate measurement frequency for the matching measurement).

When converted into the time domain, a matching measurement over the widest possible frequency range results a high resolution (e.g. 1 pixel per cm of DUT length). The mathematical models limit the time, and thus distance, that can be measured. Therefore, a compromise must be found between the display resolution and the measurable distance. To do this, the length of the

Testing Antenna Systems Using the R&S FSH

cable must be supplied to the measuring instrument before the measurement begins. The measuring instrument then calculates the appropriate frequency range (span) for the matching measurement. Please note that the operating frequency range of the DUT should be selected as the center frequency.

The following figures show how matching measurements can provide information about any discontinuities that might be present.

Experienced users can look at the shape of the measurement curve for the return loss over the frequency and conclude whether a discontinuity is present and its distance.

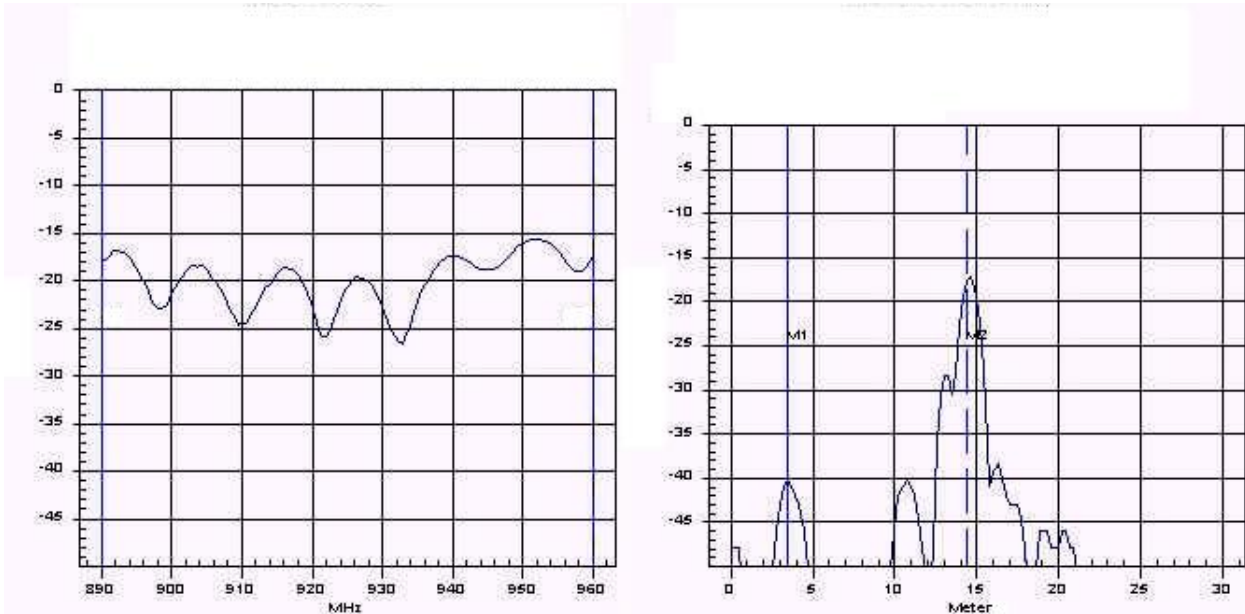

Reflection and DTF measurement for a short antenna feeder cable with a connected antenna

Please note the coarse ripples, which indicate a short cable (15 m in this case) or a nearby discontinuity at about 15 m distance.

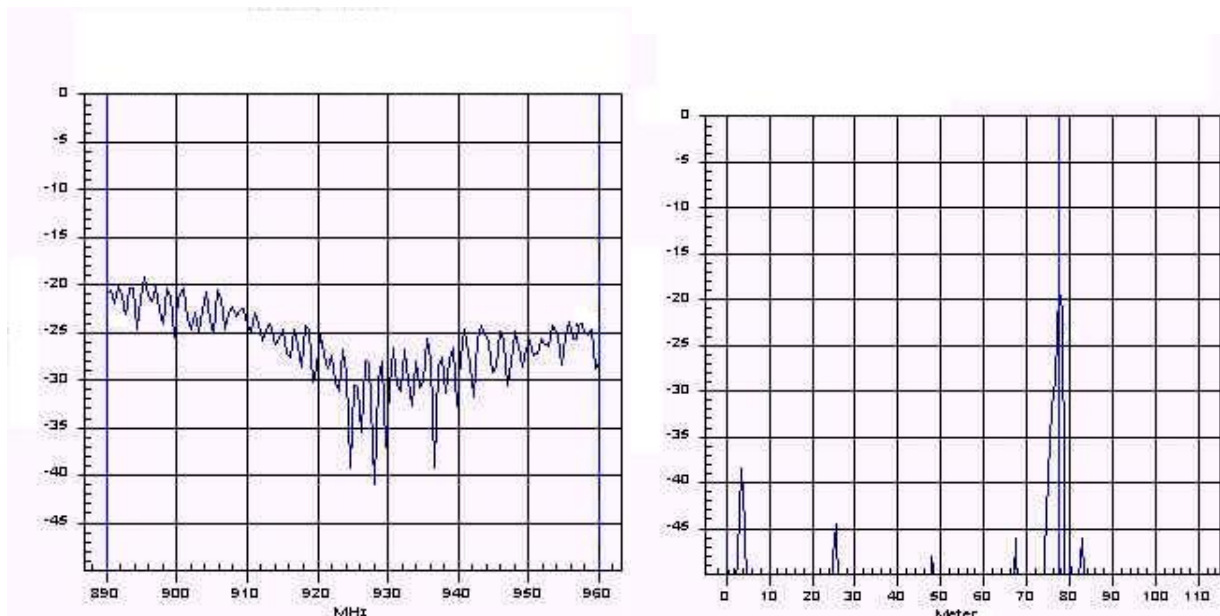

Testing Antenna Systems Using the R&S FSH

Reflection and DTF measurement for a long antenna feeder cable with connected antenna

Please note the fine ripples over the same frequency range as the last example. This indicates a longer antenna feeder cable or a discontinuity located farther away (80 m in this case).

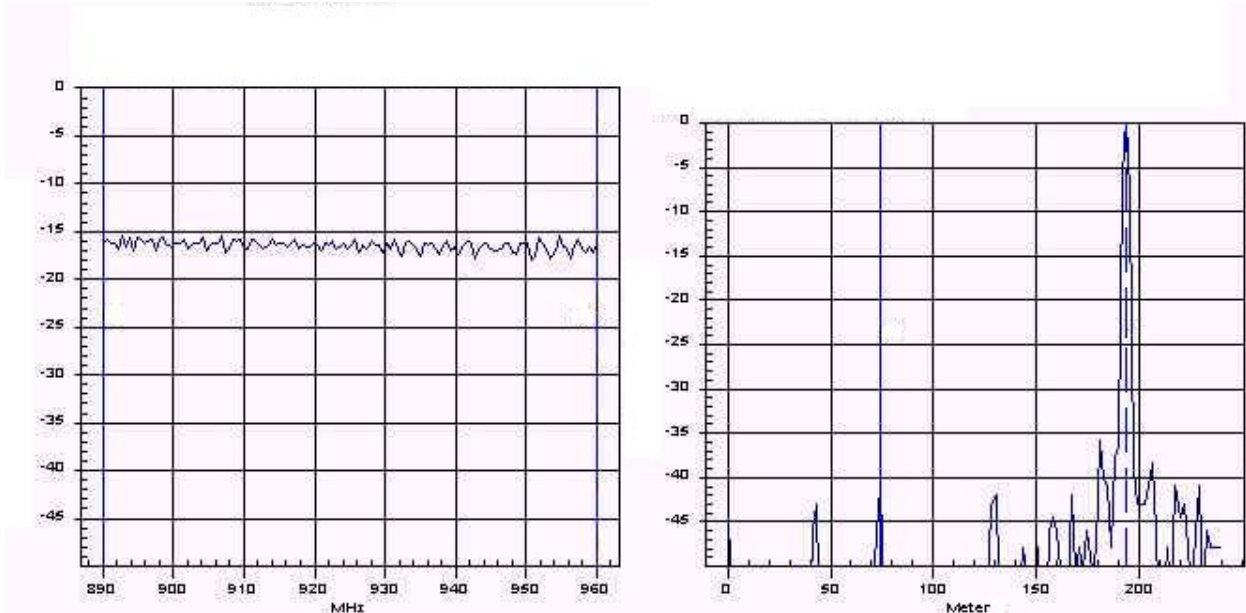

Reflection and DTF measurement for a defective (or missing) antenna (open circuit at the end)

Please note the straight matching curve over the frequency, which does not show any significant maximum or minimum.

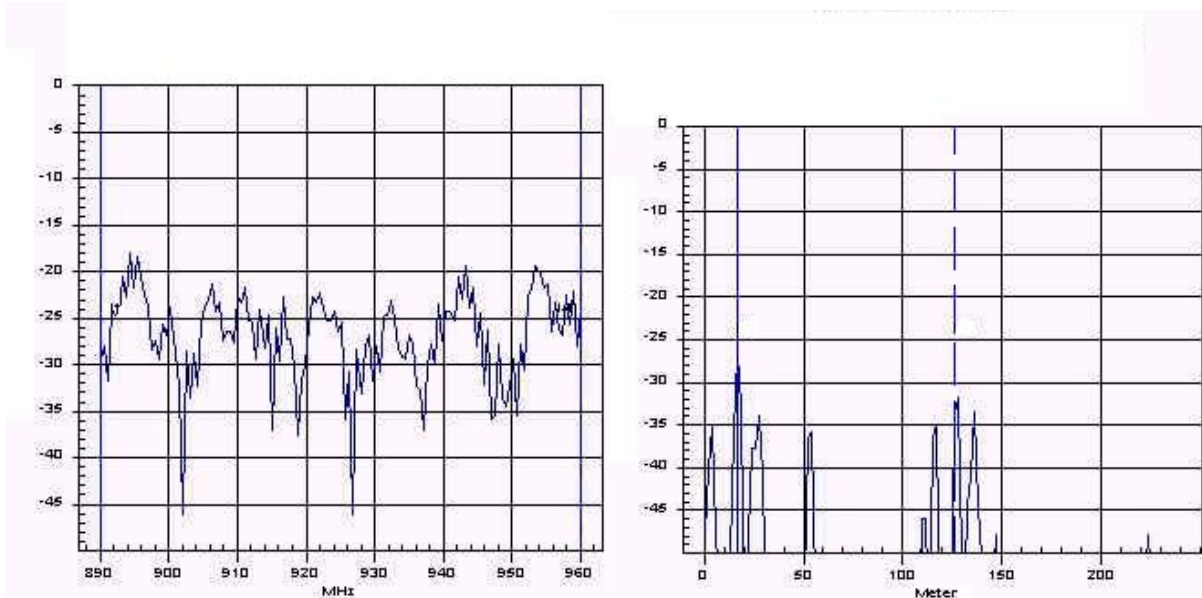

Reflection and DTF measurement for a long cable having multiple discontinuities

Please note how fine and coarse ripples are overlaid in the return loss display.

Discontinuity Measurement of Antenna Systems

Every change in the characteristic impedance in the antenna system leads to a reflection of forward RF energy and forms a discontinuity. Every plug-in connector or screw fastening, every kink in the cable, and the like can lead to a discontinuity of some significance. Compressing the cable leads to exactly two discontinuities, one at each of the sites where there is a change in the characteristic impedance:

Example: Two discontinuities resulting from a compressed coaxial cable

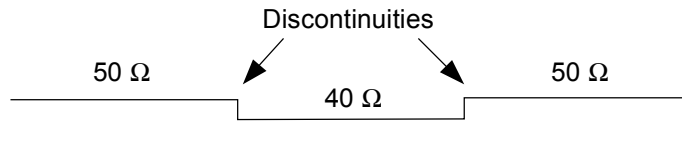

Depending on the wavelength, these two discontinuities are then recognizable in different ways. If the operating frequency of the affected antenna system is relatively high, the two discontinuities are recognizable as separate faults. If the reflected power of each discontinuity lies under a limit value, then there is no fault in the system.

However, if the operating frequency is relatively low — i.e. the wavelength of the RF signal is large relative to the distance between the discontinuities — then the two discontinuities will merge into one. In this case, the discontinuity is recognizable as a single, concentrated fault. The reflected power — as the sum of the two separate faults — will then exceed the limit value and be recognized as a fault in the antenna system.

It is therefore important that test equipment with high spatial resolution be used, and that the antenna system be measured within its operating frequency range.

To locate and evaluate the intensity of measured discontinuities, the cable loss and its velocity factor (the speed at which the wave propagates in the cable, in m/s) must be entered in the R&S FSH. Frequency-dependent cable models can be generated using the R&S FSH View software and stored in the cable model memory of the R&S FSH. The cable parameters for a defined frequency can be entered directly into the R&S FSH.

The cable loss is used to correct the return loss of the discontinuity because it becomes more significant as the cable loss increases (i.e. the farther away the fault lies). The velocity factor of the cable is used to calculate the actual distance to fault.

When cable models stored in the R&S FSH are opened, the value of the cable loss is calculated for the measurement frequency range. If the cable parameters are entered manually, please note that the cable loss value corresponds to the center frequency for the DTF measurement.

Discontinuity Measurement on Antenna Systems with Tower-Mounted Amplifier (TMA)

The discontinuity measurement is essentially identical to the measurement on systems without a tower-mounted amplifier (TMA). However, please note

that the TMA forms a discontinuity in a wide frequency range because of the built-in transmit and receive filters. Outside of their passbands, these filters indicate the total reflection during matching measurement and act as stops during the transmission loss measurement. A TMA therefore manifests itself as a large discontinuity during the discontinuity measurement.

Refer to the following section for the subsequent measurement steps, and for more detailed information about assessing the measurements carried out on 3G TMA antenna systems.

Discontinuity Measurement behind the TMA (3G)

A discontinuity measurement in the frequency range of the filter passband characteristic — i.e. through the TMA — can, with some restrictions, be used to detect faults located between the TMA and the antenna. The TMA filters have only a limited bandwidth allowing a view of the antenna. The limited bandwidth causes additional phase or group delays for the test signal, so that a DTF assessment can no longer be performed with a high degree of accuracy based on the measured delay or distance.

To allow an assessment of a TMA with a connected, properly functioning antenna, use the procedures and advice listed below, as well as the individual results from on-site system measurements.

DTF Measurement over a Wide Frequency Range (3G)

During DTF measurement of an antenna system, the basic DTF measurement should be performed with a high degree of resolution (i.e. across a wide frequency span) in order to get a good indication of faults in the feeder cable up to the TMA.

This example measures a 3G tower-mounted amplifier. The following settings were selected:

Center frequency: 2045 MHz
Frequency span: 1.256 GHz (60 m cable LDF6-50)

Setup: feeder cable (40 m LDF6-50) – TMA jumper cable (2m) – cross-polarized antenna.

The set frequency range is too wide for the passband of the TMA filters to allow an assessment of the path between the TMA and the antenna. In spite of this, the following system functions can still be assessed:

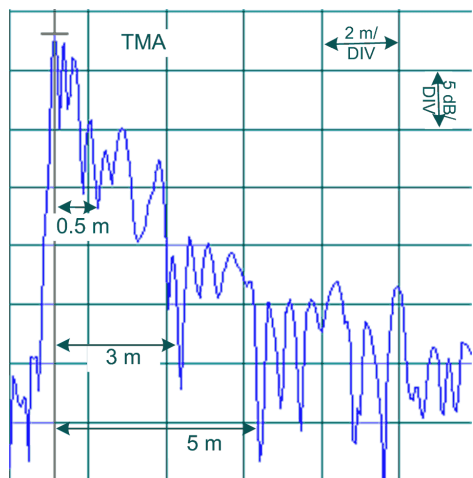

1. During the matching measurement, the antenna matching can be measured in the range of the TMA filter passband characteristics.
2. No significant discontinuities are present up to the TMA.
3. The decoupling measurement (on cross-polarized antennas) does not indicate any particular problems.
4. At jumper cable lengths of approximately 2 m between the TMA and the antenna, jumps in the DTF measurement can be found about 0.5 m and 3 m after the TMA. In addition, the outgoing wave behind the TMA is about 5 m long (see figure). The R&S FSH Zoom function is useful for viewing this.

If a different TMA is used, or if the jumper cable lengths between the TMA and antenna differ from those described here, the actual distances will be different than shown here.

DTF Measurement in the Transmit and Receive Frequency Range (3G)

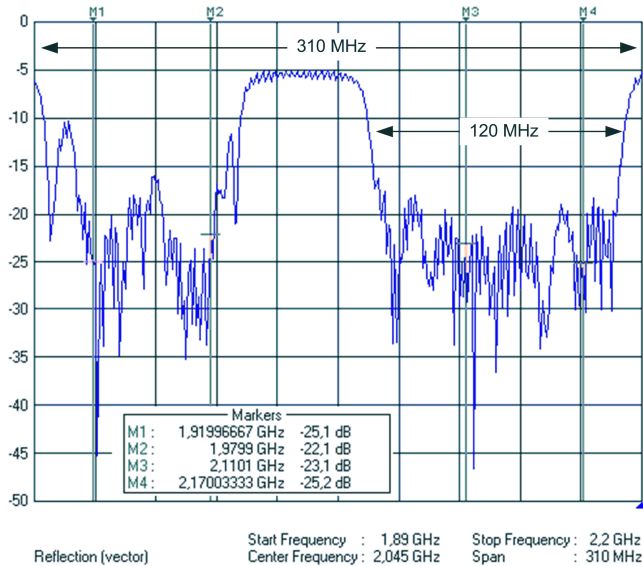

To determine the span between the TMA and the antenna, the frequency range for DTF measurement can be reduced to the 3G frequency range.

When using the UL and DL range, the maximum span is about 310 MHz (corresponds to approx. 220 m LDF4-50). The stopband for the TMA between the UL and the DL manifests itself as a discontinuity.

A DTF measurement with a center frequency of 2045 MHz and a span of 310 MHz (220m LDF4-50) in the following environment provided these results:

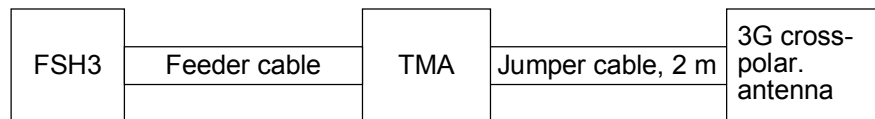

Testing Antenna Systems Using the R&S FSH

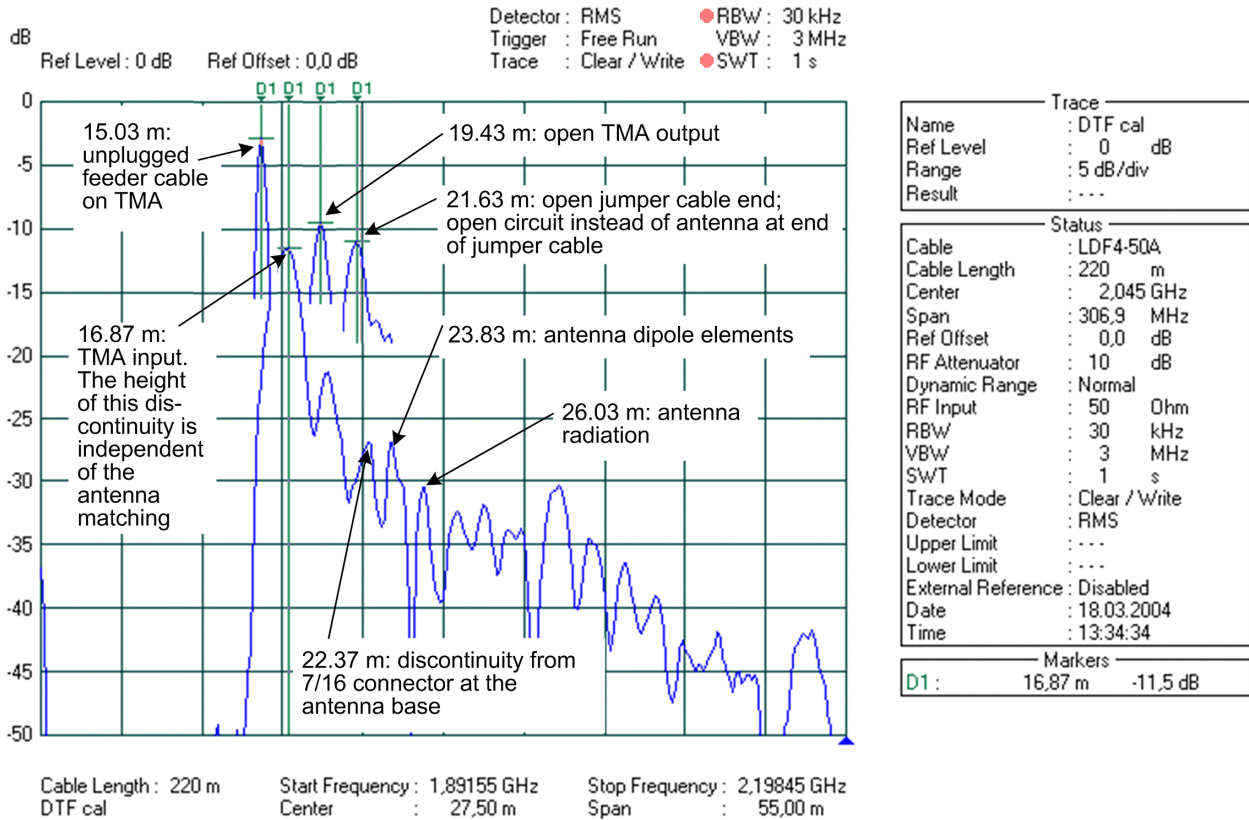

This figure shows various measurements on a single system. Of particular interest is that the size of the discontinuity at the TMA input is not dependent on the reflection factor at the TMA output. The length of the feeder cable is correctly measured at about 2 m. Visible here are the connectors at the antenna base, the antenna dipoles, and to a lesser degree the radiation of the antenna. Because the TMA indicates a discontinuity in the frequency range being used (between the transmit and receive frequency range), the components behind the TMA (in this example) indicate an overmatching of at least 7 dB. As a result, their reflection characteristics cannot be precisely assessed.

DTF Measurement Only in the Transmit Frequency Range (3G)

To further reduce the effects of the TMA and to avoid the mismatching range between the transmit and the receive frequency range, it makes sense to measure only in the transmit frequency range (DL). In addition to the wider passband characteristic, the transmit range has less insertion loss as compared to the receive frequency range.

The following example measures the same test configuration as defined above, but with a center frequency of 2120 MHz and a frequency range of about 123 MHz (550 m cable):

Testing Antenna Systems Using the R&S FSH

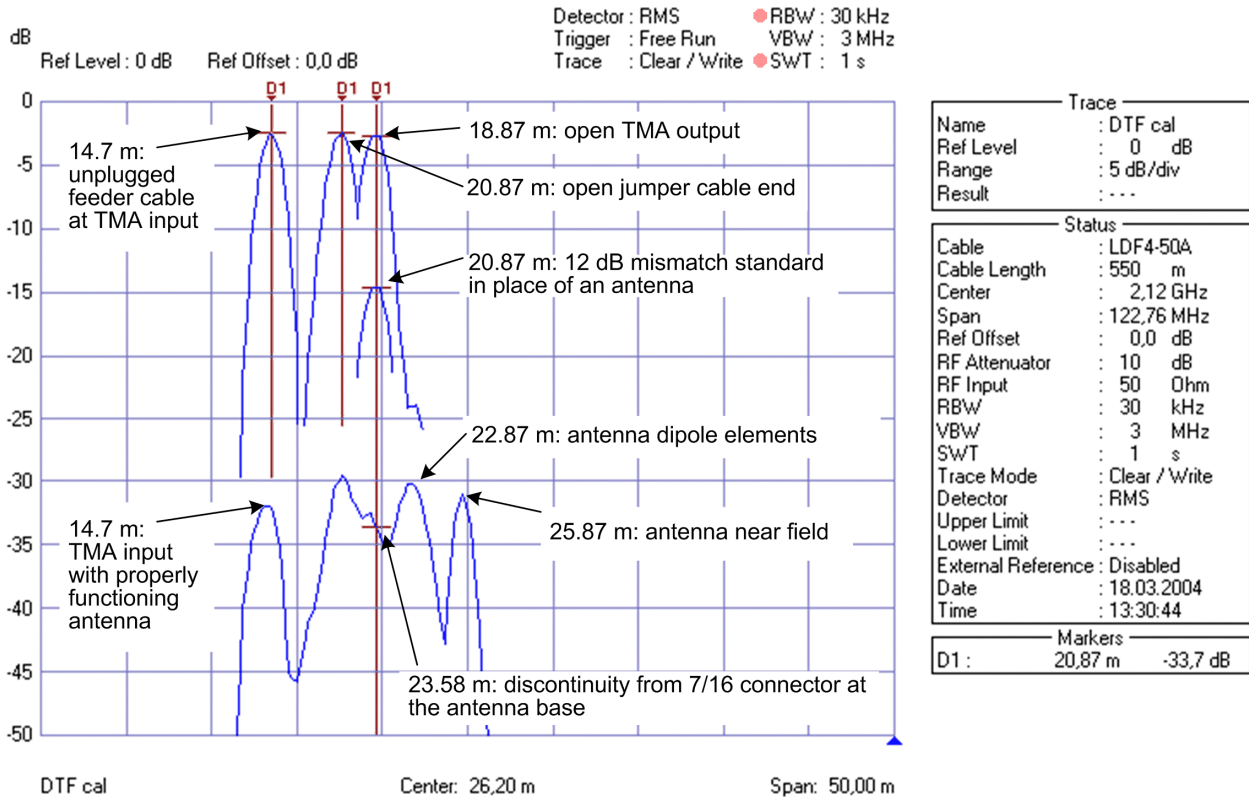

This display is a result of several measurements using the same test setup. It is clear to see that the influence of the TMA has decreased enough that the discontinuities behind the TMA can be measured (with a limited distance resolution).

The TMA input no longer represents a significant discontinuity, the length of the jumper cable is correctly measured at 2 m, and the discontinuities behind the TMA are displayed with their actual matching value. Even the antenna's 7/16 connector, its dipoles, and the formation of the antenna near field can be assessed.

This measurement is possible only by using the zoom function available in the R&S FSH and a test resolution of 1023 measurement points, making the above details visible. These types of measurements are not possible without this function.

Checking the Wavefront Formation of a Stacked Antenna

By performing the DTF measurement within the operating range of the antenna, it is possible to observe the formation of the antenna field, and thus to assess the radiation characters of the antenna.

In the case of a multiple, stacked antennas, the common wavefront from all antenna elements is initially several wavelengths away from the antenna. In the wave formation range, the DTF measurement shows discontinuity-like reflections from the antenna field. These represent the formation of a common wavefront.

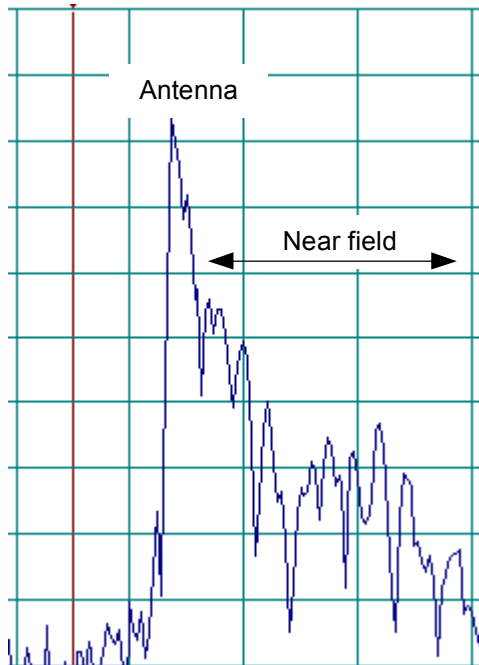

DTF measurement of a stacked antenna. The formation of the wavefront in the near field area is easily recognizable

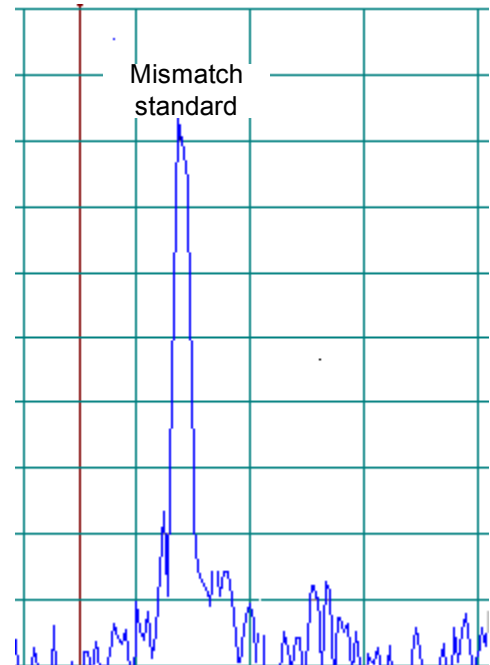

For comparison, this is a DTF measurement of a mismatch standard. No antenna field forms, and the standard appears as a concentrated discontinuity

Special Characteristics of the R&S FSH

Measurement of the Transfer Function of Active Elements

The R&S FSH measures the transfer function based on the tracking generator running synchronously with the receive frequency. The output signal from the tracking generator is a sinusoidal signal with an almost constant level. Transient effects of the active elements are therefore not relevant for the measurement, or can be avoided by matching the sweep speed. This is not the case for measurements that use a coded signal from the tracking generator, which causes a jump in the output frequency in order to suppress noise signals in the receiver using correlation. Depending on the pulse response time of the system under test, as well as the duration of the generator pulse, a gain value that is too low is measured for the active module. This is not the case with the R&S FSH.

Antenna System Measurements Influenced by RF

Reflection, discontinuity, and decoupling measurements on antenna systems can be affected by transmitters operating in the vicinity. If there is little decoupling between the transmitting antenna and the antenna under test, the transmit signal will affect the test result. For example, the interfering signal might be found in the results of the return loss measurement. The Trace Min Hold function on the R&S FSH significantly reduces the effects of interfering transmit signals (GSM, WCDMA, etc) on the display of the test result.

The following example shows the matching measurement of a cross-polarized antenna. A WCDMA signal is transmitted on the second system of this antenna. As a result of the decoupling of the two systems in this antenna of about 35 dB, a noise level of about +2 dBm is present on the bridge of the

Testing Antenna Systems Using the R&S FSH

R&S FSH, which shows up in the matching measurement as a spurious signal.

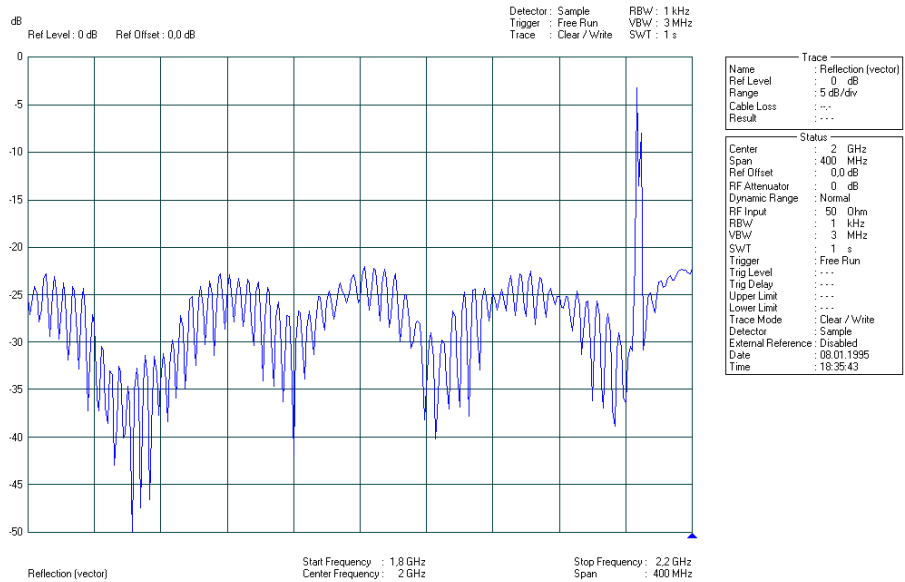

The Min Hold function of the R&S FSH considerably lessens this influence. The spurious WCDMA signal is reduced by about 15 dB after several sweeps, while the accuracy of the return loss measurement remains unaffected.

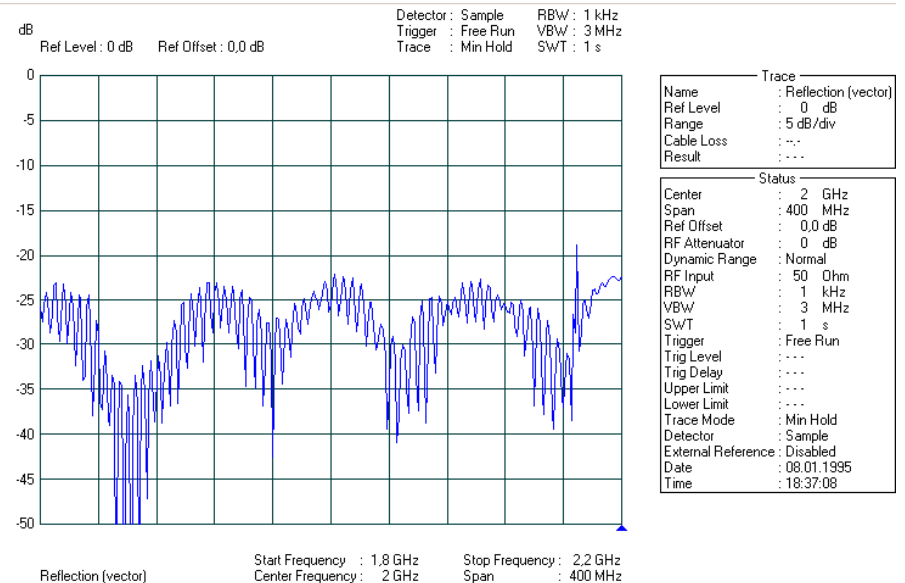

This procedure works for all spurious signals that display power minimums and maximums over time, i.e. for all mobile radio signals, such as GSM/EDGE, WCDMA, or DECT. The R&S FSH measures the current value of pulsed or modulated signals on each sweep. However, the signal from the tracking generator maintains a constant level and is not affected by the Min Hold function. Therefore, it can be used as a continuously valid reference for the measurement. This procedure can be used both for matching measurements and for transmission measurements, and makes the R&S FSH appropriate for use even in these extreme situations.

Decoupling Measurements

Decoupling Measurements of Antenna Systems

In the case of cross-polarized antennas, matching measurements alone are not sufficient to ensure the proper functioning of the antenna system. In some cross-polarized antennas, defects can be detected only by measuring the antenna decoupling. In these antenna systems, the matching measurement does not show any particular problems. The decoupling measurement of the two antenna systems, however, shows an abnormal progression over the frequency.



This picture shows an example of an antenna defect — an unsoldered cable connection — on a new antenna. This type of defect is noticed only by performing an antenna decoupling measurement:

The GSM 1800 base station in this example had an elevated call drop rate, which was due to the differing directional characteristics of the two systems contained in the antenna.

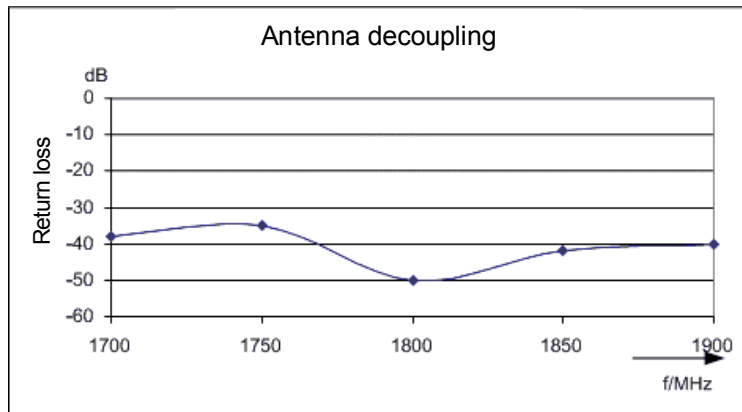

Example of a typical antenna decoupling

It is recommended that a collection of typical SX antenna decouplings be compiled in cooperation with the manufacturer and made available to the test engineers so that they can assess the status of an antenna system for a variance comparison.

The type of antenna and the defined electrical downtilt must be taken into consideration, because the decoupling characteristic over the frequency differs as a function of these factors.

Depending on the antenna type, it can also be useful to remove the electrical downtilt from the antenna — i.e. to return the antenna to its status as delivered — to make it possible to measure defined decoupling values.

Based on experience, a deviation from the nominal value of ± 3 dB should be worth further investigation.

The feeder cable loss should be taken into consideration when assessing the measured decoupling values. This cable loss increases the decoupling by the loss of both feeder cables being measured.

Antenna systems with near field interference from buildings display a different decoupling over the frequency range. This is a result of the near field interference, and is not the result of a defect.

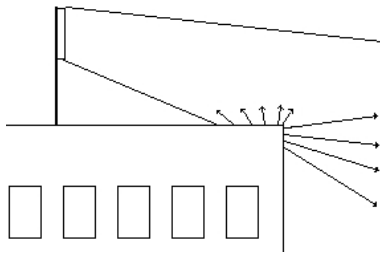

If there is interference in the first Fresnel zone, the radiation characteristics of the antenna change significantly.

This can affect the matching values, and especially the decoupling values of an antenna.

Decoupling Measurement of Antenna Systems with Tower-Mounted Amplifiers (TMA)

Like for the matching measurement, on antenna systems with tower-mounted amplifiers, only the passband of the TMA filters is available for determining the decoupling of the antenna elements. During this measurement, the TMA gain can be determined simply by connecting and disconnecting the TMA supply voltage.

The decoupling measurement of the antenna system must take into account both the cable loss of the two feeder cables and the transmission loss of the TMA. In the receive path, this loss lies in the range of 0.1 dB to 0.5 dB, depending on the TMA type. In the transmit path, it lies between 1 dB and 2 dB. The loss values must be taken into consideration for every TMA to be included in the measurement (typically two).

This diagram shows the signalling path with the built-in modules.

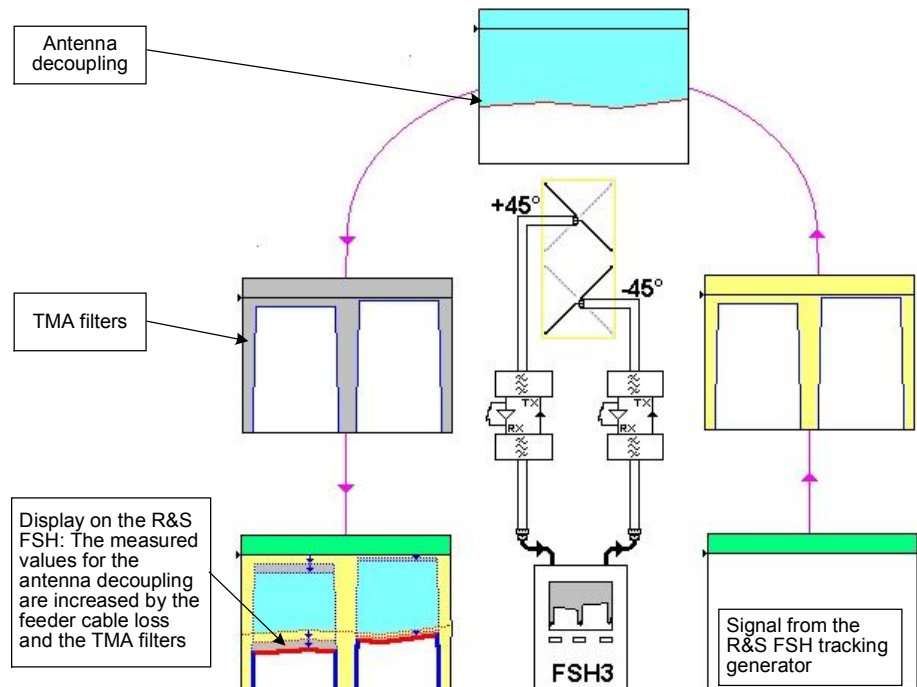

Measurement of the Tower-Mounted Amplifier (TMA) Gain

The test setup for measuring the antenna decoupling with a built-in TMA shown in the following diagram can be used in conjunction with a bias T (DC feeder switch) to determine the gain of the TMA being fed. By connecting and disconnecting the supply voltage, the gain is detected directly as the difference between the decoupling measurements in the transmit path with and without power. The bias T needed for the TMA power supply is to be inserted into the signal return path of the R&S FSH, as shown in the illustration.

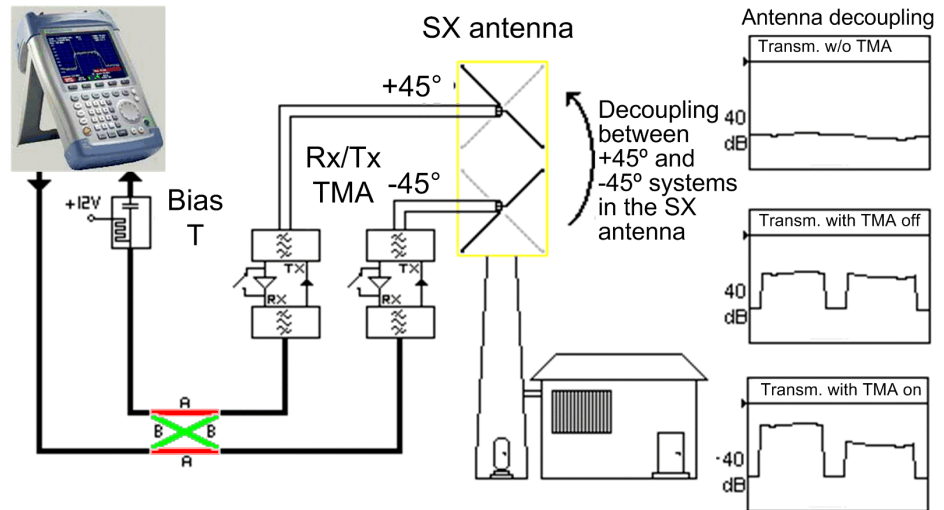

Test setup for measuring the antenna decoupling and the TMA gain

The gain of a TMA without bypass cannot be measured. However, by connecting and disconnecting the power, it is possible to determine whether the TMA is amplified.

Measurement of the Whole System Gain

The measurement of the tower-mounted amplifier described above is to be used only when testing the TMA functionality exclusively. When measuring the gain of the TMA, the components in the receive path of the mobile radio base station must also be taken into consideration. The TMA should compensate for the receive cable loss. Moreover, the TMA may not be used for excessive level gain because this can make the defined RX parameters (e.g. for detecting RX level handover or for power regulation at the mobile station) impracticable or even dangerous.

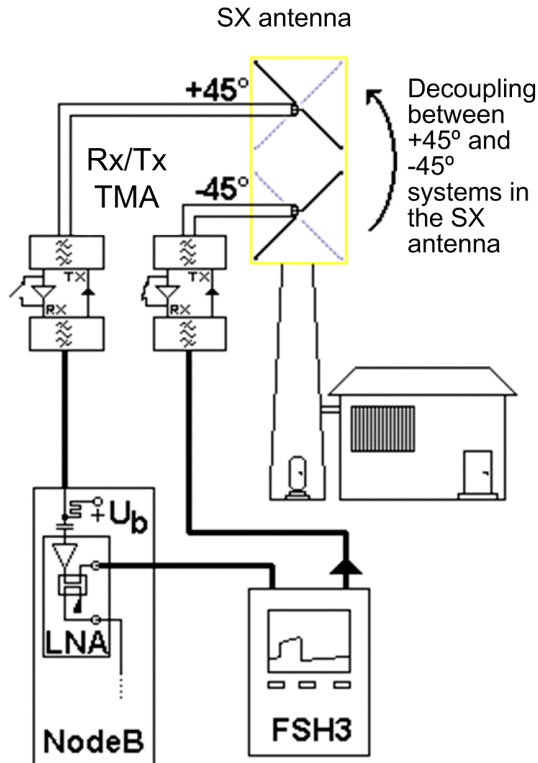

For this reason, and because the receive signal is already amplified in the TMA, the amplifiers in the receive path of base stations are generally disconnected. The functioning of the TMA can thus be assessed only in conjunction with the receive elements in the base station. Therefore, a functioning base station (base station is present and supplied with voltage) does not require the use of a bias T to feed the TMA. As shown in this figure, the measurement includes all components in the receive path and requires only the option of interrupting the power supply to the TMA by changing the NodeB configuration. This generally switches the internal LNA. This method allows the difference in the gain of the UL path under test with and without the TMA.

Depending on the system technology, the difference should lie between 0 dB and +2 dB. By disconnecting the power supply using a commercially available DC blocker, only the TMA is without current and the LNA in NodeB is generally not reconfigured.

Because of the transmit filter in NodeB, the decoupling and the gain of the TMA/whole system are to be measured only in the UL frequency range.

TMA Measurement before Installation in the Antenna System

As shown in this figure, a TMA can be measured before it is installed in the antenna system.

The measurement is based on a transmission measurement.

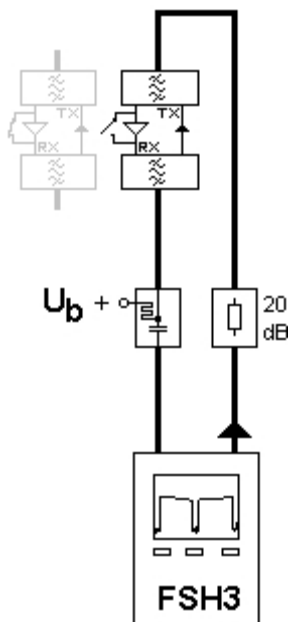

Please make sure that the input level on the antenna side of the TMA does not significantly exceed the maximum input level value specified in the TMA data sheet (generally about -40 dBm). The level of the R&S FSH tracking generator must be set to -20 dBm, and a 20 dB attenuator must be inserted between the tracking generator output and the TMA. Or, by using a 40 dB attenuator, there is no longer any need to reduce the tracking generator level.

In the case of TMAs with a high level of gain and a high output level, it might become necessary to protect the R&S FSH input by inserting an additional attenuator between the RF input of the R&S FSH and the bias T. The maximum permitted power at the R&S FSH input is +20 dBm, although +30 dBm is possible for periods of several minutes.

If an overload occurs on the TMA, an invalid, low gain value is measured because the TMA is reaching its limits.

It is possible to determine the gain of the TMA by connecting and disconnecting the supply voltage and comparing the two test results.

5 Summary of Test Procedures

This section summarizes the test procedures that should be used to accept or assess antenna systems composed of 2G or 3G base stations.

Antenna Systems without TMA

For all antenna systems:

- Return loss (RL) measurement with connected antenna.
- DTF measurement with connected antenna (measurement of the complete system). The DTF measurement shows discontinuities in the cable. If performed within the antenna's operating frequency range, the measurement also shows the formation of the antenna near field and the length of the feeder cable.

For cross-polarized sector antennas:

- Decoupling measurement of both antenna systems in the case of cross-polarized antennas. This measurement shows the electrical characteristics of these types of antennas better than a simple return loss measurement.

Antenna Systems with TMA

For all antenna systems:

- Return loss measurement with connected antenna, without power to the TMA (= traditional method of measuring the reflected power in an antenna system).
- DTF measurement with connected antenna, without power to the TMA (= measurement of the complete system). The DTF measurement shows discontinuities in the cable, the TMA, and (if performed within the operating frequency range of the antenna/TMA) discontinuities between the TMA and the antenna, as well as the formation of the antenna near field. For this measurement, the TMA may not be supplied with DC.

For cross-polarized sector antennas:

- Decoupling measurement of both antenna systems in the case of cross-polarized antennas, without power to the TMA (shows the decoupling of the antenna system through the TMA filters).
- Gain measurement of the TMA in the whole system, with power to the TMA from the base station. Measurement as described in the section "Measurement of the TMA Gain".
- If no base station is set up: Measurement of the TMA gain with external bias T as described in the section "Measurement of the Whole System Gain".

6 Example Measurements

These example measurements are based on an R&S FSH, Model 1145.5850.23 with firmware version 7.0 or higher, and with installed options R&S FSH-B1 (Distance-To-Fault Measurement) and R&S FSH-K2 (Vector Transmission and Reflection Measurements), and with the VSWR Bridge R&S FSH-Z2.

Frequency Ranges

The following frequency ranges apply for the various services:

Service		Total	UL	DL
GSM (2G)	GSM 900	880 MHz to 960 MHz	880 MHz to 915 MHz	925 MHz to 960 MHz
	GSM 1800	1710 MHz to 1880 MHz	1710 MHz to 1785 MHz	1805 MHz to 1880 MHz
UMTS (3G)	TDD / FDD	1900 MHz to 2170 MHz		
	TDD	1900 MHz to 1920 MHz		
	FDD	1920 MHz to 2170 MHz	1920 MHz to 1980 MHz	2110 MHz to 2170 MHz
	TDD	2020 MHz to 2025 MHz		

The following frequency range and marker settings are recommended for the example measurements:

Service		Start/Stop Frequencies:	Markers 1+2: (UL)	Markers 3+4: (TX)
GSM (2G)	GSM 900	875 MHz to 965 MHz	880 MHz, 915 MHz	925 MHz, 960 MHz
	GSM 1800	1700 MHz to 1890 MHz	1710 MHz, 1785 MHz	1805 MHz, 1880 MHz
UMTS (3G)	TDD / FDD	1890 MHz to 2200 MHz (Center: 2045 MHz Span: 310 MHz)	1920 MHz, 1980 MHz	2110 MHz, 2170 MHz

Once you have defined a setup, you should store it in the R&S FSH.

Antenna System without Tower-Mounted Amplifier

Matching Measurements

Test Setup:

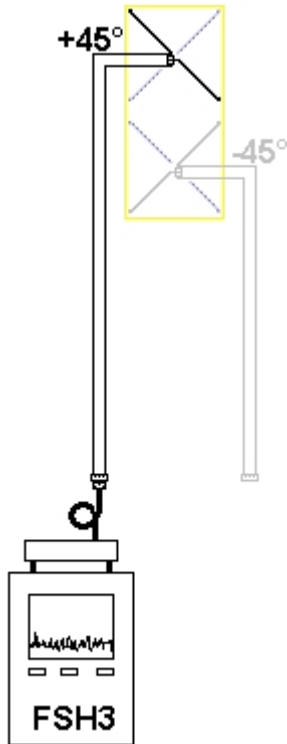

Settings on the R&S FSH:

Attach the VSWR bridge (R&S FSH-Z2) onto the R&S FSH.

Switch on the tracking generator on the R&S FSH (Key MEAS: Softkey MEASURE: Select TRACKING GEN: Press the ENTER key)

Select center frequency: based on service or operating frequency range of the antenna system (Key FREQ: Input the frequency value).

Select span: based on service (Key SPAN: Input the span value).

Select vector measurement on R&S FSH (Key MEAS: Softkey MEAS MODE: Select VECTOR: Press the ENTER key).

Calibrate measurement: Press Softkey RELECT CAL and follow instructions on R&S FSH.

Connect bridge output with antenna cable.

Remarks:

The antenna matching appears to be improved by the feeder cable loss and worsened by the energy returning from the antenna. Refer to the section "Matching Measurement Errors".

The ripples in the matching measurement can indicate possible discontinuities. Refer to the section "Introduction to DTF and Discontinuity Measurements"

Example Measurement:

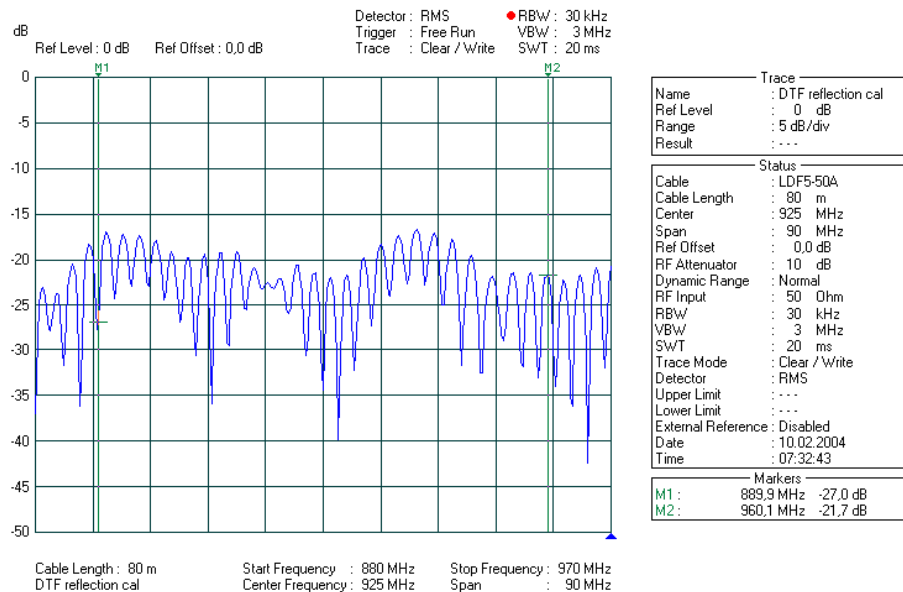

DTF Measurements

Test Setup:

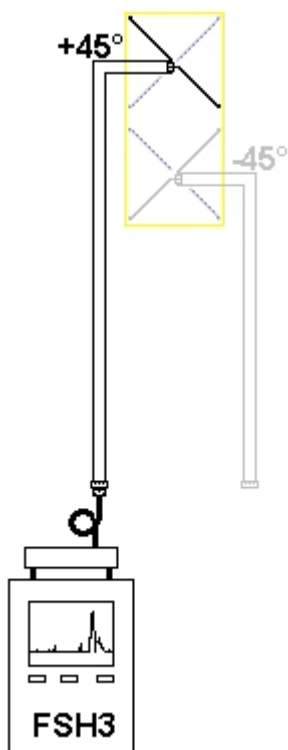

Settings on the R&S FSH:

Attach bridge (R&S FSH-Z2) onto the R&S FSH.

Attach the 1 m forward cable to the bridge input.

Start DTF measurement on R&S FSH (Key MEAS: Softkey MEASURE: Select DISTANCE TO FAULT: Press the ENTER key)

Select center frequency: based on service or operating frequency range of the antenna system (Key FREQ: Input the frequency value).

Select span: based on service (Key SPAN: Input the span value).

Input cable parameter or select cable type from the list (Key MEAS: Softkey CABLE MODEL: Select cable type: Softkey SELECT).

Cable length: Input as approx. 30% longer than actual so that effects behind the TMA can be observed (Softkey CABLE LENGTH: Input the length: Press the ENTER key).

Calibrate measurement: Press softkey DTF CAL and follow instructions on R&S FSH.

Connect R&S FSH forward cable to antenna cable.

Remarks:

The Zoom function offered by the R&S FSH allows detailed observation of individual stops.

When measuring with reduced span (approximately the operating frequency range of the antenna), the formation of the antenna near field can be evaluated.

Example Measurement:

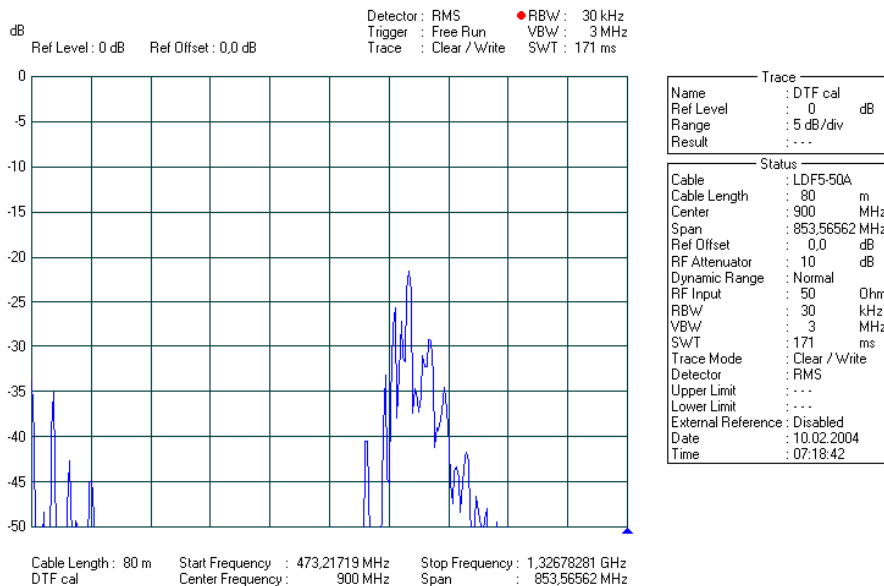

Decoupling Measurement

Test Setup:

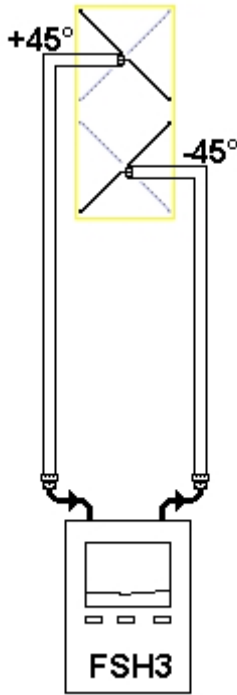

Settings on the R&S FSH:

Remove bridge (R&S FSH-Z2).

Switch on the tracking generator on the R&S FSH (Key MEAS: Softkey MEASURE: Select TRACKING GEN: Press the ENTER key).

Select center frequency: based on service (Key FREQ: Input the frequency value).

Select span: based on service (Key SPAN: Input the span value).

Select vector measurement on R&S FSH (Key MEAS: Softkey MEAS MODE: Select VECTOR: Press the ENTER key).

Calibrate measurement: Press softkey TRANSM CAL and follow instructions on R&S FSH.

Connect RF input and tracking generator output with the cable connectors of the antennas under test.

Remarks:

In this measurement, the feeder cable loss of both feeder cables must be taken into consideration.

The results of the decoupling measurement are to be compared against the decoupling specified for the antenna type (manufacturer specifications) at a defined electrical downtilt. Deviations in the linearity of the characteristic and in the absolute values can indicate faults in the antenna near field, or it can indicate a defective antenna.

Example Measurement:

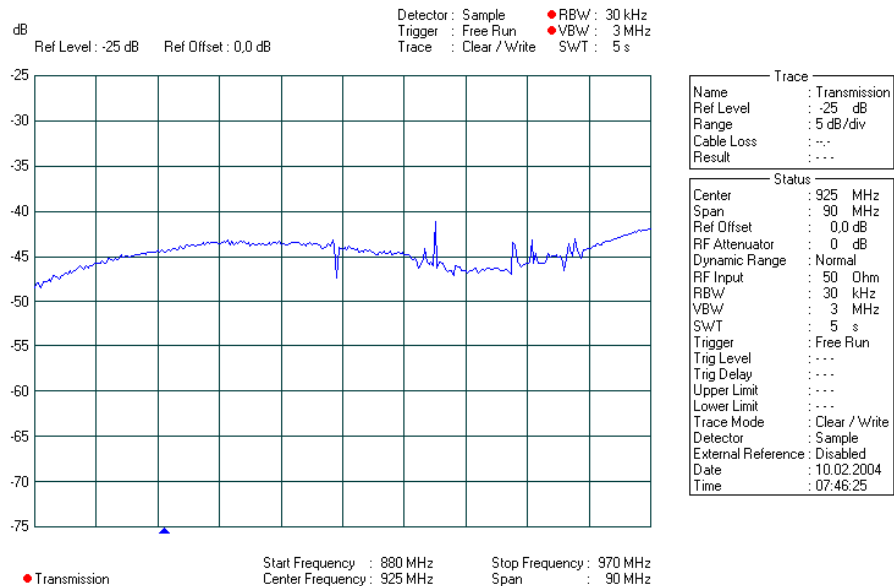

Antenna Systems with Tower-Mounted Amplifier

Matching Measurements

Test Setup:

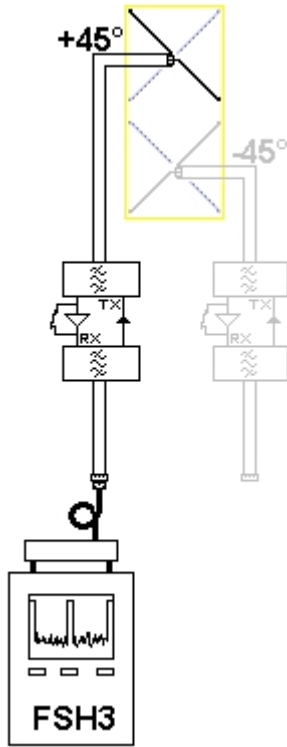

Settings on the R&S FSH:

Attach bridge (R&S FSH-Z2) onto the R&S FSH.

Switch on the tracking generator on the R&S FSH (Key MEAS: Softkey MEASURE: Select TRACKING GEN: Press the ENTER key)

Select center frequency: based on service or operating frequency range of the antenna system (Key FREQ: Input the frequency value).

Select span: based on service (Key SPAN: Input the span value).

Select vector measurement on R&S FSH (Key MEAS: Softkey MEAS MODE: Select VECTOR: Press the ENTER key).

Calibrate measurement: Press softkey RELECT CAL and follow instructions on R&S FSH.

TMA feed: none

Connect bridge output with antenna cable.

Remarks:

The antenna matching is improved by the feeder cable loss and the TMA and worsened by the energy returning from the antenna.

The antenna matching can be detected only in the passbands of the TMA filters.

Refer to section "Matching Measurement of Antenna Systems with a Tower-Mounted Amplifier (TMA)".

Example Measurement:

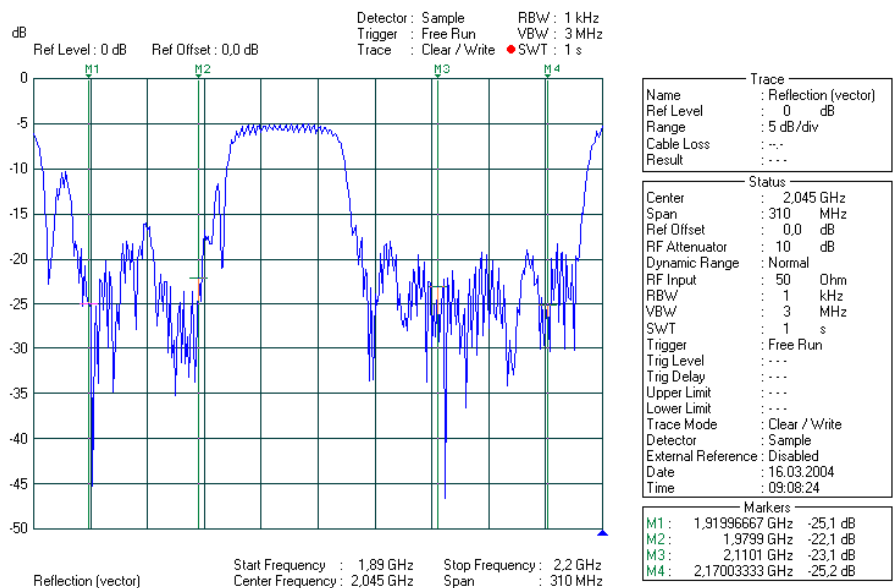

DTF Measurements

Test Setup:

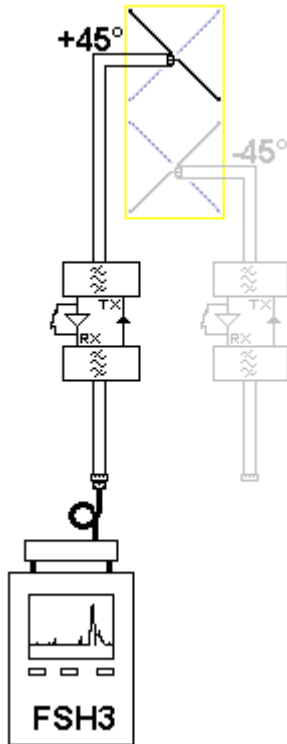

Settings on the R&S FSH:

Attach bridge onto the R&S FSH.

Attach the 1 m forward cable to the bridge input.

Switch on the DTF measurement on the R&S FSH (Key MEAS: Softkey MEASURE: Select DISTANCE TO FAULT: Press the ENTER key)

Select center frequency: based on service or operating frequency range of the antenna system (Key FREQ: Input the frequency value).

Input the cable parameters or select cable type from the list (Key MEAS: Softkey CABLE MODEL: Select cable type: Softkey SELECT).

Cable length: Input as approx. 30% longer than actual so that effects behind the TMA can be observed (Softkey CABLE LENGTH: Input the length: Press the ENTER key).

Calibrate measurement: Press softkey DTF CAL and follow instructions on R&S FSH.

TMA feed: none

Connect R&S FSH forward cable with the antenna cable.

Remarks:

The Zoom function offered by the R&S FSH allows detailed observation of individual discontinuities.

During the measurement, only the range between the TMA and the antenna can be checked for discontinuities by matching the center frequency and the frequency span. Refer to section "Discontinuity Measurement behind the TMA".

Example Measurement:

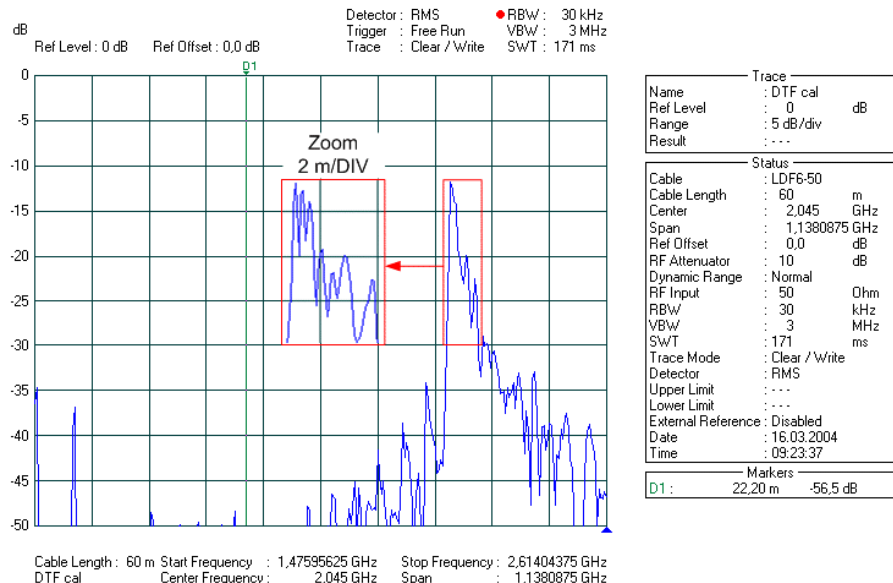

Decoupling Measurement

Test Setup:

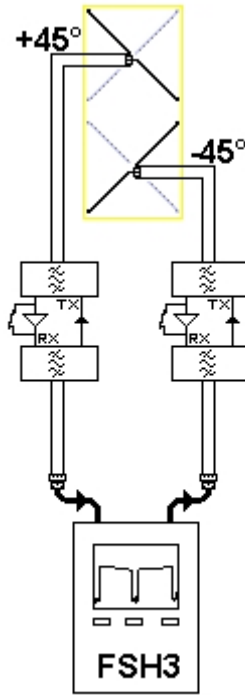

Settings on the R&S FSH:

Remove bridge.

Switch on the tracking generator on the R&S FSH (Key MEAS: Softkey MEASURE: Select TRACKING GEN: Press the ENTER key).

Select center frequency: based on service (Key FREQ: Input the frequency value).

Select span: based on service (Key SPAN: Input the span value).

Select vector measurement on R&S FSH (Key MEAS: Softkey MEAS MODE: Select VECTOR: Press the ENTER key).

Calibrate measurement: Press softkey TRANSM CAL and follow instructions on R&S FSH.

TMA feed: none

Connect RF input and tracking generator output with the cable connectors of the antenna under test.

Remarks:

In this measurement, the feeder cable loss of both feeder cables and the attenuation from both TMAs (which will differ in the UL and DL ranges!) must be taken into consideration.

The antenna decoupling can be detected only in the passbands of the TMA filters.

The results are to be compared against the decoupling specified for the antenna type (manufacturer specifications) at a defined electrical downtilt.

Example Measurement:

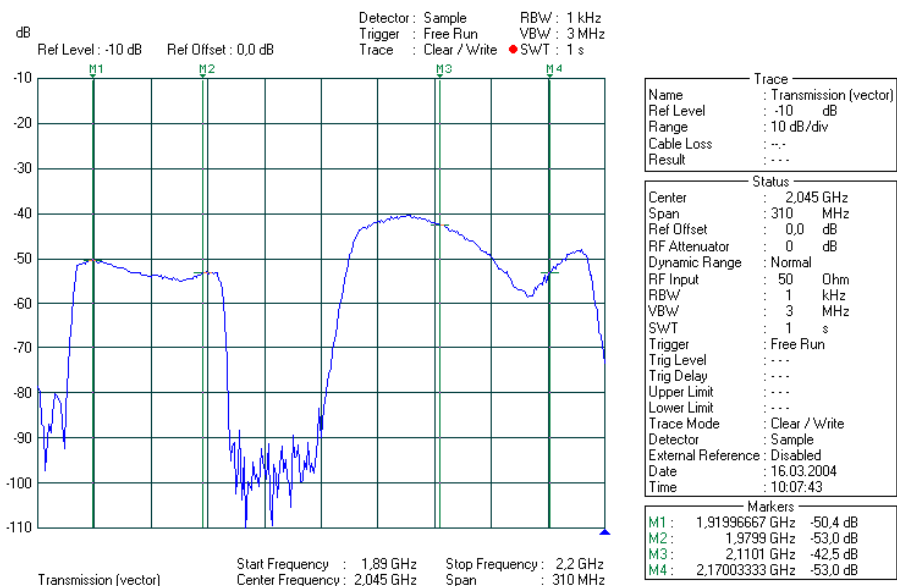

Measurement of the TMA Gain

Test Setup:

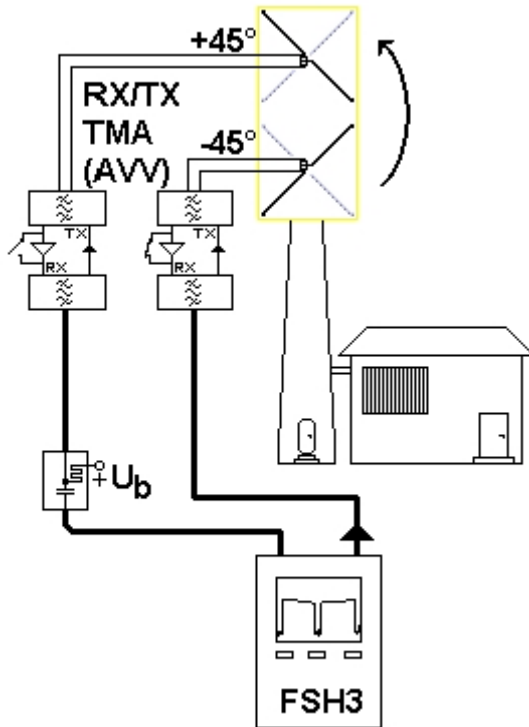

Settings on the R&S FSH:

Remove bridge.

Switch on the tracking generator on the R&S FSH: Key MEAS: Softkey MEASURE: Select TRACKING GEN: Press the ENTER key.

Select center frequency: based on service (Key FREQ: Input the frequency value).

Select span: based on service (Key SPAN: Input the span value).

Select vector measurement on R&S FSH: Key MEAS: Softkey MEAS MODE: Select VECTOR: Press the ENTER key.

Calibrate measurement: Press softkey TRANSM CAL and follow instructions on R&S FSH.

TMA feed: With external bias T.

Connect RF input and tracking generator output with the cable connectors of the antenna under test.

Remarks:

The TMA gain can be determined by connecting and disconnecting the TMA power. This measurement can be performed in combination with the antenna decoupling measurement as described in the preceding section.

Example Measurement:

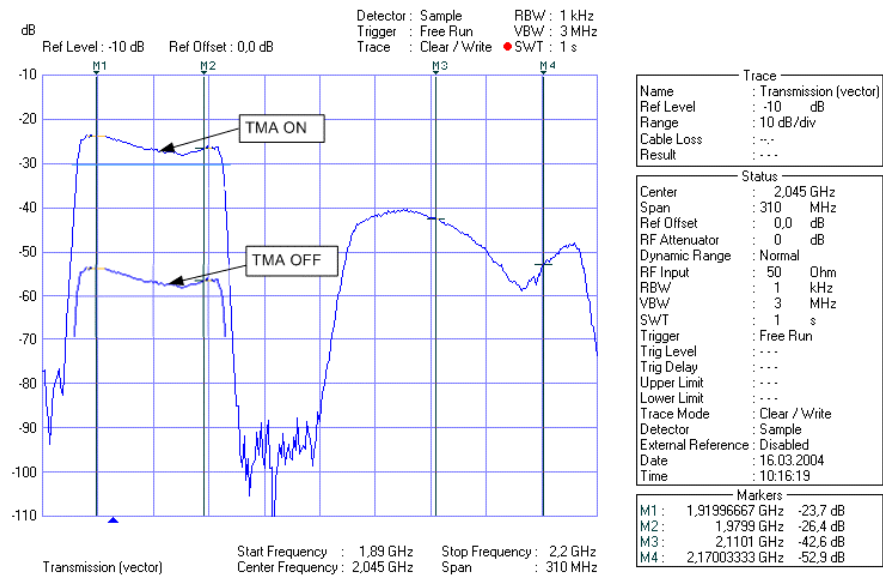

Measurement of the Whole System Gain

Test Setup:

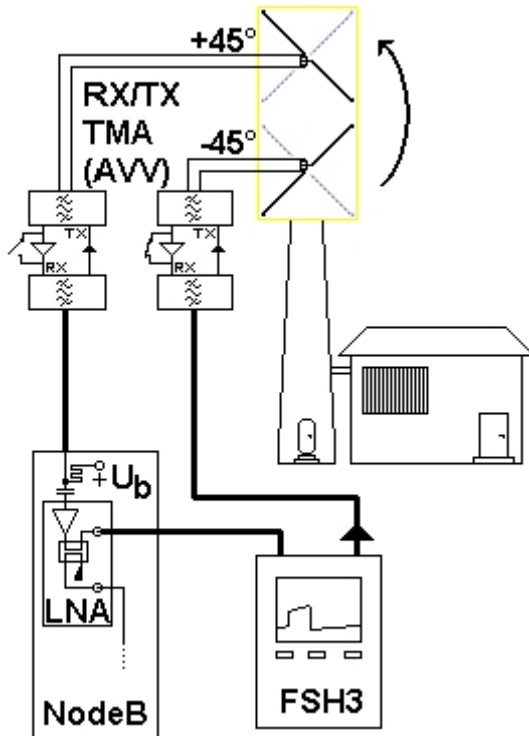

Settings on the R&S FSH:

Remove bridge.

Switch on the tracking generator on the R&S FSH: Key MEAS: Softkey MEASURE: Select TRACKING GEN: Press the ENTER key.

Select center frequency: based on service (Key FREQ: Input the frequency value).

Select span: based on service (Key SPAN: Input the span value).

Set reference level to -10 dB: Key AMPT: Input -10: Press the ENTER key.

Select vector measurement on R&S FSH: Key MEAS: Softkey MEAS MODE: Select VECTOR: Press the ENTER key.

Calibrate measurement: Press softkey TRANSM CAL and follow instructions on R&S FSH.

TMA feed: Via the base station

Remarks:

The TMA gain can be determined in conjunction with the whole system by connecting and disconnecting the TMA power. In this measurement, only the UL range can be detected because of the UL filter installed in the system.

Example Measurement:

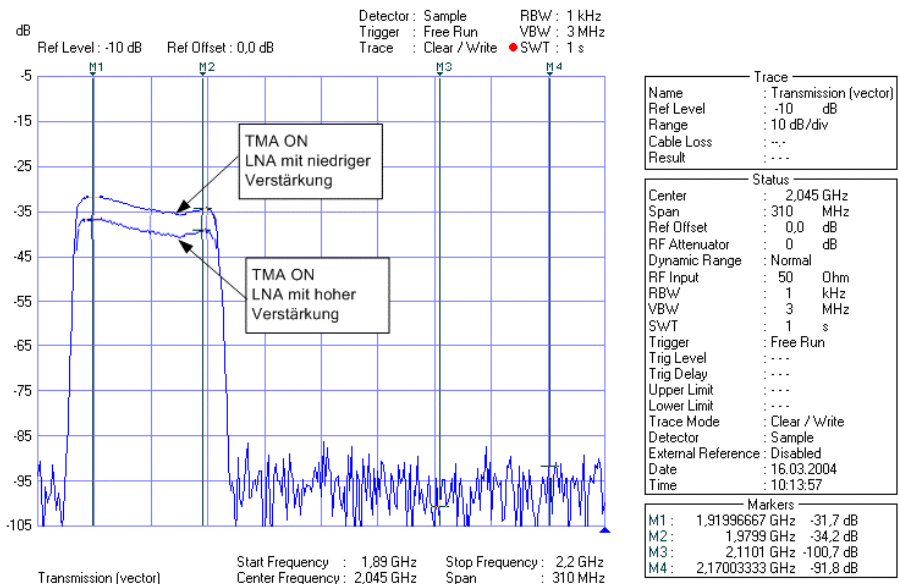

Measurement of the TMA Gain at Ground

Test Setup:

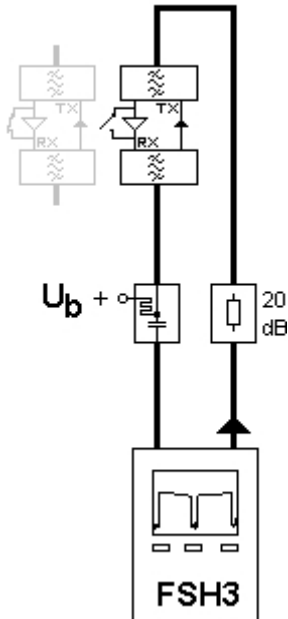

Settings on the R&S FSH:

Remove bridge.

Switch on the tracking generator on the R&S FSH: Key MEAS: Softkey MEASURE: Select TRACKING GEN: Press the ENTER key.

Set output level of the tracking generator to -20 dBm.

Select center frequency: based on service (Key FREQ: Input the frequency value).

Set reference level to $+10$ dB: Key AMPT: Input $+10$: Press the ENTER key.

Select vector measurement on R&S FSH: Key MEAS: Softkey MEAS MODE: Select VECTOR: Press the ENTER key.

Calibrate measurement: Press softkey TRANSM CAL and follow instructions on R&S FSH.

TMA feed: Via external bias T

Attach a 20 dB attenuator to the tracking generator output of the R&S FSH.

Remarks:

The TMA gain can be determined before it is installed in an antenna system by connecting and disconnecting the TMA power.

A suitable attenuator should be used at the TMA input to protect the TMA against overloads.

Example Measurement:

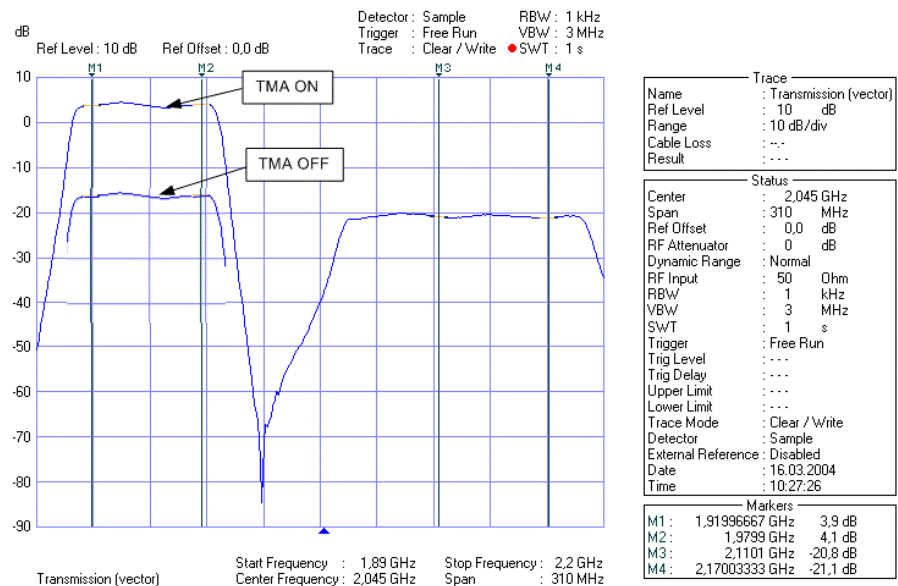

7 Additional Information

Note Regarding Defective Antennas

Matching and decoupling measurements cannot preclude the possibility of a defect in the antenna system. Even though nothing suspicious might be detected in either measurement, it is still possible that the transmit and receive characteristics of the antenna will be unsatisfactory.

The following measurements can be used to search for defective antennas producing insufficient radio coverage:

- RX function test (analysis of the mobile station's transmit power referenced to the DL level).
- Checking the DL levels on different GSM channels of the base station. It is possible that the DL levels on the channels in a defective antenna system are higher or lower than those on the properly functioning system.
- For GSM, does an intracellular handover occur shortly after the TCH assignment? The level of the affected channel could be too low because of antenna problems, and therefore the channel would be faulty because of interference.
- Reciprocal UL-DL relationship at the horizontal limits of the antenna diagram.
- The field strength in the coverage area of the antenna is too low as compared to the theoretical value, i.e. the antenna usually displays a squint (see below).

Asymmetry of the Directional Lobe over the Frequency

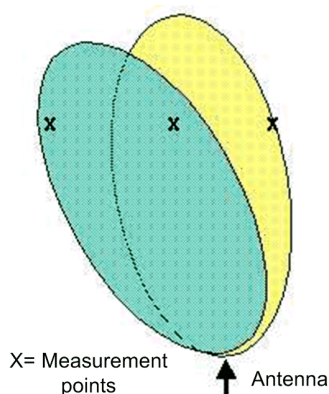

A defective antenna can exhibit the following behaviour:

Depending on the location, the DL level is vastly different for frequencies far apart (e.g. GSM channels 20 and 100) and is possibly even inverted when a measurement is performed on the opposite side of the antenna diagram.

The UL/DL level symmetry is very different at the opposite sides of the antenna diagram, sometimes even inverted.

Please note that the antenna can develop a significant squint, i.e. the main radiation direction can differ considerably from the nominal value!

8 Abbreviations

DL	<u>D</u> own <u>l</u> ink (transmit direction of the BTS)
DTF	<u>D</u> istance <u>t</u> o <u>f</u> ault Measurement
FDR	Frequency domain reflectometer
LNA	Low noise amplifier
RL	Return loss
Rx	Receiver
SX	cross-polarized
TDR	Time domain reflectometer
TMA	Tower-mounted amplifier
Tx	Transmitter
UL	<u>U</u> plink (transmit direction of the mobile station)

9 Ordering Information

Equipment Type		Order Number
R&S FSH3	Handheld Spectrum Analyzer 100 kHz to 3 GHz with Tracking Generator	1145.5740.13
R&S FSH3	Handheld Spectrum Analyzer 100 kHz to 3 GHz with Tracking Generator and Preamplifier	1145.5740.23
R&S FSH6	Handheld Spectrum Analyzer 100 kHz to 6 GHz with Tracking Generator and Preamplifier	1145.5850.26
R& FSH-B1	Distance to Fault Measurement for R&S FSH	1145.5750.02
R&S FSH-K2	Vector Reflection and Transmission Measurement for R&S FSH	1157.3387.02
R&S FSH-Z2	VSWR Bridge for R&S FSH, 10 MHz to 3 GHz	1145.5767.02



ROHDE & SCHWARZ GmbH & Co. KG · Mühldorfstraße 15 · D-81671 München · P.O.B 80 14 69 · D-81614 München ·
Telephone +49 89 4129 -0 · Fax +49 89 4129 - 13777 · Internet: <http://www.rohde-schwarz.com>

This application note and the supplied programs may only be used subject to the conditions of use set forth in the download area of the Rohde & Schwarz website.